

## **ELIA Transmission Belgium**

### **PROCEDURE FOR CONSTITUTION OF STRATEGIC RESERVE**

**Applicable for the tendering in 2021 as of the Ministerial Decree to constitute Strategic Reserve for the Winter Period 2021-2022**

**In accordance with article 7<sup>quinquies</sup>, §1, of the Law of 29 April 1999 concerning the organisation of the electricity market, ELIA determines and publishes the modalities of the Procedure for Constitution of Strategic Reserve after consulting grid users, distribution system operators, the regulator and the General Direction Energy.**

# Contents

	<b>Preface</b>	<b>4</b>
	<b>Definitions</b>	<b>5</b>
	<b>Background</b>	<b>12</b>
<b>1</b>	<b>Strategic Reserve</b>	<b>14</b>
<b>2</b>	Tendering schedule for 2021	14
<b>3</b>	Consulting stakeholders	15
<b>3</b>	Entry into force and duration	15
<b>3</b>	Hierarchy of documents	16
<b>4</b>	Ministerial Decree on the determination of volumes	16
4.1	<b>Initial required volume</b>	<b>16</b>
4.2	<b>Possible revision volume</b>	<b>16</b>
4.3		
4.4		
4.5	<b>Delivery Points</b>	<b>17</b>
4.5.1	Requirements for TSO Submetering Delivery Points	18
4.5.2	<b>Technical requirements for TSO Submetering Delivery Points</b>	<b>18</b>
<b>5</b>	<b>Providing ELIA with Submetering data for TSO Submetering Delivery</b>	
5.1	<b>Points</b>	<b>18</b>
5.1.1	<b>Compliance of Submetering facilities at sites connected to the ELIA</b>	
5.1.2	<b>Grid</b>	<b>19</b>
5.1.3	Requirements for Delivery Points within a Closed Distribution System connected to the ELIA Grid	20
5.2	Requirements for DSO Submetering Delivery Points	21
5.3	<b>Technical requirements for DSO Submetering Delivery Points</b>	<b>21</b>
5.3.1	<b>Providing ELIA with Submetering data for DSO Submetering Delivery</b>	
5.3.2	<b>Points</b>	<b>21</b>
5.3.3	<b>Compliance of Submetering facilities at sites connected to the DSO grid</b>	<b>21</b>
<b>6</b>	<b>Shared Connection Points</b>	<b>22</b>
6.1	From SGR to Shared Connection	22
6.2	Requirements for a shared Connection Point	22
<b>7</b>	<b>Stages of the tendering procedure</b>	<b>23</b>
7.1	Call for Candidates	23
7.1.1	<b>Contract Notice and Admission process</b>	<b>23</b>
7.1.2	<b>Application file for SGR and SDR Candidates</b>	<b>24</b>
7.2	Certification	27
7.2.1	<b>Certification of SGR Power Plant(s)</b>	<b>27</b>
7.2.2	<b>Certification of SDR Reference Power</b>	<b>28</b>
7.2.2.1	Metering data for Certification of SDR Reference Power	28
7.2.2.2	Certification request practicalities	29
7.2.2.3	Certification of Emergency Generators	31
7.2.2.4	Exclusivity criteria governing the combination SDR DROP-TO, SDR DROP-BY and/or other ancillary services on a Delivery Point	31
7.2.2.5	Determination of the maximum Reference Power	32
7.3	Call for Tender	34
7.3.1	<b>Launch of Call for Tender</b>	<b>34</b>
7.3.2	<b>SGR/SDR Contract</b>	<b>34</b>
7.3.2.1	Relationship between the SGR Contract and other contracts	35
7.3.2.2	Subject of the SGR Contract	35
7.3.2.3	Relationship between the SDR Contract and other contracts	35
7.3.2.4	Subject of the SDR Contract & Functioning Rules	36
7.3.2.5	<b>Structure of offers (bidding sheets &amp; bidding instructions)</b>	<b>36</b>
7.3.3.1	Bidding principles for SGR Candidates	36
7.3.3.2	Bidding principles for SDR Candidates	36
7.3.3.3	Bidding sheets	37

	<b>Contractual Data form .....</b>	<b>38</b>
	Final Offer	39
	<b>Conditions for the submission of the offers .....</b>	<b>39</b>
	<b>Data &amp; additional documents to be added to the offer .....</b>	<b>39</b>
	<b>Validity of the offers.....</b>	<b>39</b>
	Awarding	40
	Contracting	41
	<b>7.3.4 Contract conclusion process.....</b>	<b>41</b>
7.4	<b>Conditions for starting the SDR or SGR Service .....</b>	<b>41</b>
	<b>7.4.1 Contract award notice .....</b>	<b>41</b>
	<b>7.4.2 .....</b>	<b>41</b>
	<b>7.4.3 .....</b>	<b>41</b>
7.5	<b>Return to the market.....</b>	<b>42</b>
7.6	<b>7.6.1 General principles of return to the electricity market.....</b>	<b>42</b>
	<b>7.6.2 Reimbursement of costs that have been remunerated in the context of an SGR</b>	
7.7	Contract	42
<b>8</b>	<b>Rules regarding disputes .....</b>	<b>42</b>
	8.1	
	8.2	
	<b>Cancelling the tendering procedure .....</b>	<b>43</b>
<b>9</b>	<b>Modification of the instruction of the Minister.....</b>	<b>43</b>
<b>10</b>		
<b>11</b>	<b>Questions</b>	<b>43</b>
<b>12</b>		

## Preface

This document describes the tendering of strategic reserve for the Winter Period 2021-2022, which starts as of 1 November 2021.

**1** This Procedure for Constitution of Strategic Reserve and the tendering that is organised via this procedure are established under article 7<sup>quinquies</sup> §1 of the Electricity Law from 29 April 1999 (hereafter "Electricity Law").

The mechanism is part of the measures with which the Federal Minister of Energy (hereafter "the Minister") wanted to create a framework from 2014 onwards, based on the Electricity Law, to ensure a certain level of security of supply during the Winter Period. The mechanism was approved by the European Commission after investigation in accordance with the "Guidelines on State aid for environmental protection and energy 2014-2020" (EEAG) up to and including Winter 2021-2022<sup>1</sup>.

---

<sup>1</sup> State Aid Case SA.48648 Belgian Strategic Reserve  
[http://ec.europa.eu/competition/ejojade/isef/case\\_details.cfm?proc\\_code=3\\_SA\\_48648](http://ec.europa.eu/competition/ejojade/isef/case_details.cfm?proc_code=3_SA_48648)

## Definitions

2

<b>Access Contract</b>	The contract <sup>2</sup> (or equivalent) concluded between ELIA (resp. DSO) and the ELIA Grid (resp. Distribution Grid) access holder (in accordance with the applicable Grid Code) which specifies the conditions governing the granting of access to the ELIA Grid (resp. Distribution Grid) for the Access Point.
<b>Access Point</b>	An Injection and/or Offtake Point to the Transmission or DSO Grid.
<b>Activation</b>	<p>Instruction from ELIA for a SR Unit to undertake actions by this Unit in respect of the injection of electricity into the grid or the reduction of an offtake as described at §6.2.2 for SGR and §6.3.1 for SDR. An activation can happen as a result of a Technical Trigger or to test the well-functioning of a unit (the first two cases are "Real Activations" and the third a "Test Activation").</p> <p>A Test Activation is always due to ELIA's instructions for a unit; either at the request of ELIA or at the request of the SGR/SDR supplier operating this unit. An Activation is considered complete when the various phases (going from the "Warm-up" to "Effective Delivery" phase, described in §7.2.2 and §7.3.2) have been completed. In other words, an Activation canceled by ELIA at the end of the Warm-up period (i.e. the first phase of an activation) is not complete.</p>
<b>Admission</b>	An SDR and/or SGR Candidate must pass an Admission procedure in order to participate in the Call for Tender; they can only take part in the Admission procedure if they send an application file during the Call for Candidates. ELIA will check whether the application file satisfies certain conditions and will grant Admission if it does so. Only offers submitted by SDR and/or SGR Candidates that have passed the Admission procedure will be accepted in the Call for Tender.
<b>BRP</b>	As defined in art. 2(7) of the decree (EU) 2017/2195 <sup>3</sup> .
<b>BRP Contract</b>	The contract concluded between ELIA and an BRP in accordance with art. 219 and 220 of the Federal Grid Code.
<b>Baseline (or Reference Curve)</b>	As defined in the Transfer of Energy Rules <sup>4</sup> .
<b>Black Start</b>	The service as defined in art. 2, 54° of the Federal Grid Code.

<sup>2</sup> The CREG-approved Access Contract to the ELIA Grid is available at : <https://www.elia.be/en/customers/access/access-contract>

<sup>3</sup> Available at : <https://eur-lex.europa.eu/legal-content/EN/TXT/?uri=CELEX%3A32017R2195>

<sup>4</sup> Available at: <https://www.elia.be/en/electricity-market-and-system/electricity-market-facilitation/transfer-of-energy>

<b>Candidate SGR Power Plant</b>	A combination of (or a single) Production Unit(s), that include(s) one or more generators for generating electricity, able to generate electricity independently of other existing Production Units or Power Plants in the market, and offered in the SGR Candidate's final offer for providing the SGR Service.
<b>Call for Candidates</b>	First phase of the strategic reserve tendering procedure, during which all interested parties, can declare their interest in participating in the Call for Tender by submitting an application file.
<b>Call for Tender</b>	Period during which all SDR and SGR Candidates that have passed the Admission procedure can submit offers, taking into account the results of the Certification of SGR Power Plants and the Certification of SDR Reference Power, the SGR and/or SDR Contract and bidding instructions.
<b>CDS (Closed Distribution System)</b>	As defined in art. 2 §1 3° of the Federal Grid Code. For the purpose of these Specific Conditions, CDS refers to CDS connected to the ELIA Grid;
<b>CDS Access Point</b>	As defined in the ELIA Access Contract.
<b>CDS Metering Technical Information Checklist</b>	Template document compiled by ELIA which SDR Suppliers, offering from CDS Delivery Points, must complete with technical information about their metering facility/facilities. This document is also used to demonstrate that the minimum technical requirements established by ELIA for the metering facility/facilities are fulfilled. The document is available on ELIA's website : <a href="https://www.elia.be/en/electricity-market-and-system/document-library">https://www.elia.be/en/electricity-market-and-system/document-library</a>
<b>CDS Operator</b>	A natural or legal person appointed by the relevant authority as the operator of the Closed Distribution System as defined in the Access Contract.
<b>Certification of SDR Reference Power</b>	Process of defining a maximum SDR Reference Power for a submitted (combination of) Delivery Point(s).
<b>Certification of SGR Power Plant</b>	Process whereby the Candidate SGR Power Plants that comply with one of the criteria set out in art. 7 quinquies §2 (2° to 4°) of the Electricity Law, are certified to deliver SGR.
<b>CIPU Contract</b>	The contract for the Coordination of Injection of Production Units concluded with ELIA <sup>5</sup> , or any other regulated contract(s) that will replace the CIPU Contract, in accordance with the dispositions in art. 377 of the Federal Grid Code.
<b>Configuration</b>	The composition used by a (Candidate) SGR Power Plant, consisting of one or more Production Units in a certain relationship, to generate power.

<sup>5</sup> Available at: <https://www.elia.be/en/electricity-market-and-system/system-services/how-to-become-an-outage-planning-and-scheduling-agent>

<b>Contract Notice</b>	A notice published on the Tenders Electronic Daily website ( <a href="http://ted.europa.eu/">http://ted.europa.eu/</a> ) inviting all parties to declare their interest in participating in the Call for Tender.
<b>Control Area</b>	The area inside which the grid operator permanently controls the balance between demand and supply of electricity, taking account of the exchanges of active power between control areas.
<b>CREG</b>	The federal regulating body of gas and electricity markets in Belgium.
<b>DAM Price</b>	Day Ahead Market price.
<b>Data Logger</b>	A device that collects/records the meter's pulse output so that it can be acquired by a metering data management system.
<b>Delivery Point</b>	Point on the electricity grid from which the SDR Service is delivered, linked to the meter(s) through which ELIA can check and measure the delivery of the SDR service as defined in chapter 5 "Delivery Points".
<b>Delivery Test</b>	Test activation <b>during</b> the run of the SDR or SGR Contract that tests the well-functioning of the SDR or SGR Service under the conditions as stipulated in the SDR or SGR Contract. Delivery Tests at the request of ELIA are remunerated. Delivery Tests at the request of the SDR or SGR Supplier are <b>not</b> remunerated.
<b>Public Distribution Grid (DSO-grid)</b>	As defined in Art. 2, 49° of the Federal Grid Code.
<b>Distribution System Operator (DSO)</b>	A natural personal or legal entity appointed by the designated regional regulator or regional authority, who is responsible for the exploitation, the maintenance and, if necessary, the development of the Public Distribution Grid in a certain zone and, where applicable, for its interconnectors with other systems and who is responsible of guaranteeing the long-term ability of the Public Distribution Grid to meet reasonable demands for electricity distribution.
<b>Emergency Generator (EG)</b>	As defined in article 2, 68° of the Electricity Law.
<b>Electricity Law</b>	The law of 29 April 1999 regarding the organisation of the electricity market; the law is amended from time to time.
<b>ELIA</b>	ELIA Transmission Belgium NV, the operator of the ELIA Grid.
<b>ELIA Grid</b>	The electricity grid to which ELIA holds the property right or at least the right of using and operating it, and for which ELIA has been appointed as system operator;
<b>Flexibility Service Provider (FSP)</b>	As defined in article 2, 64 ° of the Electricity Law.

<b>Functioning Rules of the Strategic Reserve</b>	Document that sets the Functioning Rules of the Strategic Reserve according to art. 7septies, §1 et 2 of the Electricity law. The 2021-2022 Functioning Rules are published on the ELIA website <sup>6</sup> .
<b>General Direction Energy</b>	The General Direction Energy of the Federal Public Service Economy, SMEs, Self-Employed and Energy, as defined in art. 2, 28° of the Electricity Law.
<b>General Terms &amp; Conditions</b>	The General Terms & Conditions governing strategic reserve when the SDR and/or SGR Contract is concluded, which are available on ELIA's website : <a href="https://www.elia.be/en/electricity-market-and-system/document-library">https://www.elia.be/en/electricity-market-and-system/document-library</a>
<b>Federal Grid Code</b>	The provisions of the Royal Decree of 22 April 2019, as amended from time to time, establishing a federal technical regulation for the management of and access to the transmission grid.
<b>Grid User Declaration</b>	The official declaration of the Grid User provided to ELIA, containing proof of the agreement between the SDR Provider and the Grid User to provide the SDR Service at one (or more) specific Delivery Point(s).
<b>Headmetering</b>	The recording of active energy, as defined in art. 2 §1 (4) of the Federal Grid Code, by means of a Headmeter.
<b>Headmeter</b>	A (group of) meter(s), as defined in art. 2 §1 (5) of the Federal Grid Code, associated with the Access Point as determined by ELIA, or the DSO (for the Public Distribution Grid), installed by ELIA for the ELIA Grid and the DSO for the Public Distribution Grid.
<b>Injection</b>	The injection of active power as measured at the Delivery Point. The term injection is used to designate a certain sense of energy flow and does not exclusively refer to the technical means with which the SR Service is provided.
<b>Local Production</b>	As defined in art. 1, 38 of the Federal Grid Code.
<b>Minister</b>	The federal minister responsible for energy.
<b>Ministerial Decree</b>	Decree issued by the Minister.
<b>Non-CIPU Technical Unit</b>	A resource other than production units subject to a CIPU Contract capable of providing upward and / or downward regulation power.
<b>Offtake</b>	Value indicating the offtake of active power at a Delivery Point. The term offtake is used to designate a certain sense of energy flow and does not exclusively refer to the technical means with which the SR Service is provided..

<sup>6</sup> Available at: <https://www.elia.be/en/electricity-market-and-system/document-library>



<b>Pmax Ref</b>	A unique value (expressed in MW) corresponding to the maximum power that a SGR Power Plant can produce technically and that can inject in the grid at the level of its access point at 15 °C and 1 atm, based on the technical characteristics delivered by the manufacturer and the topology of the electricity grid of the unit.
<b>Procedure for Constitution of Strategic Reserve</b>	The present document, established by ELIA after consulting the grid users, Distribution System Operators, CREG and the Federal Public Service Energy in accordance with article 7 <sup>quinquies</sup> §1 and §6 of the Electricity Law.
<b>Production Unit</b>	A physical unit that contains a generator that generates electricity and that is associated with an Access Point on the Elia Grid.
<b>Reservation Price</b>	Reservation Price per MW and per hour requested by the Candidate to provide either the SGR Service with one or more Power Plant(s) in a given Configuration, or the SDR Service for a given offered combination of Delivery Points. The Reservation Price is only paid during the Winter Period. This reservation price may not contain any anticipated cost for activation, nor the reservation cost for any potential Black Start service.
<b>SDR Candidate</b>	A person, company or organisation that is interested in participating in the Call for Tender and submitting a final offer to supply strategic reserve by means of demand according to art. 7 <sup>quinquies</sup> § 2, 1° of the Electricity Law.
<b>SDR Contract</b>	Contract between ELIA and the SDR Supplier for the supply of strategic reserve by means of demand as stipulated in art. 7 <sup>quinquies</sup> § 2, 1° of the Electricity Law.
<b>SDR DROP-BY</b>	SDR Service whereby, in the event of activation, the SDR Supplier pledges to reduce its Offtake by the contractually fixed amount of SDR Reference Power, Rref.
<b>SDR DROP-TO</b>	SDR Service whereby, in the event of activation, the SDR Supplier pledges to reduce its Offtake to the contractually fixed total Shedding Limit SDR, $SL_{SDR}$ .
<b>SDR Reference Power (Rref)</b>	As defined in the 2021-2022 Functioning Rules.
<b>SDR Service</b>	Delivery of strategic reserve by a reduction of the consumption on the demand side (including the possible injections of Emergency Generators) as referred to in article 7 <sup>quinquies</sup> § 2, 1 ° of the Electricity Law.
<b>SDR Supplier</b>	A person, company or organisation that has been awarded an SDR Contract in this tendering procedure.

<b>SDR Unit</b>	A combination (aggregation) of electrical facilities consisting of Offtakes and injections of Emergency Generators in supply points with which the total decrease (electricity consumption) of the SDR unit can be reduced by stopping, changing or delaying the energy consumption processes of these Offtakes in the delivery points, as well as by calling for an increase in electricity production by Emergency Generators, and for which an SDR contract has been concluded between ELIA and the SDR Supplier for the relevant SDR unit.
<b>SGR Candidate</b>	A person, company or organisation that is interested in participating in the Call for Tender and submitting a final offer to supply strategic reserve with a given Candidate SGR Power Plant(s) according to art. 7 quinquies §2, 2° to 4° of the Electricity Law.
<b>SGR Contract</b>	Contract between ELIA and the SGR Supplier for the supply of strategic reserve by means of one or more SGR Power Plant(s) as foreseen in art. 7 quinquies §2, 2° to 4° of the Electricity Law.
<b>SGR Power Plant</b>	A combination of (or a single) Production Unit(s) that include(s) one or more generators for generating electricity, able to generate electricity independently of other existing Production Units or power plants in the market, and subject of an SGR Contract concluded between ELIA and the SGR Supplier.
<b>SGR Service</b>	Supply of Strategic Reserve by means of SGR Power Plants as foreseen in art. 7 quinquies §2, 2° to 4° of the Electricity Law.
<b>SGR Supplier</b>	A person, company or organisation that has been awarded an SGR Contract in this tendering procedure.
<b>Shedding Limit or <math>SL_{SDR}</math></b>	A limit that represents a power level (expressed in MW) to which the Supplier with an SDR DROP TO contract commits to reduce the consumption (including the injection of Emergency Generators) of his Delivery Point(s) in case of activation.
<b>Simulation Test</b>	Test activation <b>before</b> the start (i.e. entry into force) of the SDR or SGR Contract where, at an agreed time and date, the SDR or SGR Supplier must demonstrate that they are able to fulfil the technical requirements stipulated in the SDR or SGR Contract. This test is <b>not</b> remunerated by ELIA. ELIA will ask to carry out a Simulation Test to check the correct delivery of the service.
<b>Specifications</b>	All of the documents comprising the contract, namely the Functioning Rules, the Procedure for Constitution, the SGR, SDR DROP-TO and SDR DROP-BY Contracts and the General Terms & Conditions.
<b>Submetering</b>	The recording of active energy, as defined in Art. 2 §1 (4) of the Federal Grid Code, by means of a Submeter.

<b>Submeter</b>	Either a meter, as defined in art. 2 §1 (5) of the Federal Grid Code, situated downstream of the Headmeter; or, an equation between one or more meter(s) situated downstream the Headmeter and/or the Headmeter.
<b>Submetering Technical Information Checklist</b>	Template document compiled by ELIA which SDR Suppliers must complete with technical information about their Submetering facility/facilities for Delivery Points connected to the ELIA Grid. This document is also used to demonstrate that the minimum technical requirements established by ELIA for the Submetering facility/facilities are fulfilled. This document is available on ELIA's website : <a href="https://www.elia.be/en/electricity-market-and-system/document-library">https://www.elia.be/en/electricity-market-and-system/document-library</a>
<b>Transfer of Energy Rules</b>	As defined in art. 19bis §2 of the Electricity Act.
<b>Unsheddable Margin or UM<sub>SDR</sub></b>	Minimum value, defined in case of SDR DROP-BY, of net active power Offtake (including the possible injection of Emergency Generators) that cannot be curtailed (inflexible or unsheddable power) at the Delivery Point(s) concerned (or the SDR Unit to which it belongs).
<b>Winter Period</b>	The period from 1/11 of a given year to 31/03 of the following year, as defined by the Electricity law. Hereinafter "Winter Period Y-Y+1" accounts for the Winter Period ranging from 1/11 of year Y to 31/03 of year Y+1.
<b>Working Day</b>	Any calendar day except for Saturday, Sunday and Belgian public holidays.

## Background

In 2014, a mechanism called 'strategic reserve' was introduced in the Electricity Law to ensure a sufficient level of security of supply during Winter Periods. The standard procedure and timeframes required to allow for the constitution of a strategic reserve are as follows:

- 3
  - Prior to the probabilistic analysis of ELIA the Federal Public Service Energy makes all information that is useful for the analysis and of which it possesses available to the grid operator.
  - ELIA must perform a probabilistic analysis by 15 November each year regarding the country's security of supply for the next Winter Period.
  - By 15 December each year, the General Direction Energy must provide the Minister an opinion on the need to establish a strategic reserve. If the opinion concludes that such a need exists it will also suggest the required volume.
  - The Minister may, within a period of one month from the receipt of the advice of the General Direction Energy, give instructions by means of a Ministerial Decree to ELIA to establish a strategic reserve for a period of one year, from the first day of the coming Winter period. In accordance with these instructions, ELIA is responsible for the organization of the constitution of a strategic reserve, without prejudice to the King's authority, if necessary, to impose the necessary prices and volumes by Ministerial Decree.
  - ELIA shall determine the tendering rules via a Procedure for Constitution of strategic reserve after consulting the grid users, CREG and the General Direction Energy, and shall initiate this procedure within one month after being instructed to do so by the Minister. At the latest on the same day of the launch of the procedure, the CREG will publish on its website the criteria on which the assessment of whether or not the nature of the offers is manifestly unreasonable will be based.
  - Market actors belonging to at least one of the categories identified in the Electricity Law, who have assets located in the Belgian Control Area and who meet the criteria of this Procedure for Constitution of Strategic Reserve, may take part in the strategic reserve; some of them are even obliged to submit an offer.
  - ELIA shall report to CREG and the Minister on the offers received and deemed regular within at the latest 10 Working Days after the offer submission deadline.
  - The CREG will issue a reasoned recommendation to the Minister and ELIA no later than thirty working days after receipt of the quotation report. It will be stated in a substantiated manner whether or not the prices proposed by the SGR and SDR Suppliers are manifestly unreasonable.
  - By no later than 1 September of each year, the Minister has the possibility, on the basis of an updated analysis of ELIA and advice from the General Direction Energy, by means of a Ministerial Decree deliberated in the Council of Ministers to review the required volume of the strategic reserve, both in an upward and downward direction.
  - After this date (1 September), Elia will make a techno-economical selection of the offers found as not manifestly unreasonable by the CREG and will contract the bids included in this selection, to the extent of the volume that was determined. All other offers (including the offers of which the price was found manifestly unreasonable by the CREG) will be rejected.
  - If the selection is insufficient to reach the required volume, ELIA will send a report to the Minister, the General Direction Energy and to the CREG with regard to the necessary additional volume by 15 September at the latest.

- After receiving the report from ELIA, the General Direction Energy has ten working days to send a proposal to the Minister of a techno-economical selection concerning the candidate SGR and SDR Suppliers whose prices and volumes should be imposed.
- The Minister may, based on the proposal of the General Direction Energy, impose the necessary prizes and volumes on one or more candidate/candidates of these SGR and/or SDR Suppliers for a period of one year by Ministerial Decree deliberated in the Council of Ministers.

ELIA proposes the Functioning Rules and submits them to CREG for approval. This document describes the Operating rules for the reservation and the activation of assets contracted as strategic reserve, and also serve to minimise the impact of strategic reserve on the operation of the associated electricity markets.

**Please note:** The above paragraphs are only meant to provide an indicative overview of the deadlines. Exact dates may vary as some deadlines are expressed as “number of Working Days” after a certain other deadline.

## Strategic Reserve

### Tendering schedule for 2021

The important dates for the tendering of 2021 are listed in the table below.

- 4 Please note:** This table is only meant to provide an indicative overview of the tendering procedure. The precise applicable deadlines as referred to in chapter 7 of this document take precedence over this table. Legal deadlines are put **in bold**, other deadlines are planned in order to be able to comply with legal ones but could vary with a couple of days.
- 4.1**

When	What	Who
<b>15/12/2020</b>	<b>The General Direction Energy gives an advice on the need to establish a strategic reserve, which is the starting date for the calendar hereunder.</b>	General Direction Energy ⇒ Minister
<b>&lt;= 15/01/2021</b> <b>&lt;= within one month after the opinion the General Direction Energy</b>	The Minister <b>instructs</b> ELIA to launch the constitution of the strategic reserve for a determined volume and duration.	Minister
<b>&lt;= 15/02/2021</b> <b>&lt;= at the latest one month after the decision by the Minister</b>	<b>Call for Candidates:</b> ELIA informs the market of the upcoming Call for Tender via a <b>Contract Notice</b> .	ELIA ⇒ Market
<b>&lt;= 05/03/2021</b>	Deadline for the submission of application files for the Admission procedure.	Potential SGR and SDR Candidates ⇒ ELIA
<b>&lt;= 15/03/2021</b>	ELIA initiates the <b>Call for Tender</b> for strategic reserve.	ELIA ⇒ all SGR and SDR Candidates who passed the Admission procedure
<b>&lt;= 02/04/2021</b>	Submission of the <b>request for Certification of SDR Reference Power</b> .	SDR Candidates ⇒ ELIA
<b>&lt;= 23/04/2021</b>	<b>Certification</b> issuing	ELIA ⇒ SDR Candidates
<b>&lt;= 14/05/2021</b> <b>&lt;= at the latest three months after the Call for Candidates</b>	<b>Deadline for the submission of final offers</b> for strategic reserve.	SGR and SDR Candidates ⇒ ELIA
<b>&lt;= 04/06/2021</b> <b>&lt;= at the latest 10 Working Days after submission of offers</b>	Report with all offers, justifications, prices and volumes, offered for strategic reserve.	ELIA ⇒ CREG + Minister
<b>&lt;= 16/07/2021</b>	An explicit and motivated <b>opinion</b> indicating whether or not the price of the offers deemed	CREG ⇒ ELIA + Minister

<b>&lt;= at the latest 30 Working Days after submission of report by ELIA</b>	regular by the system operator is manifestly unreasonable or not.	
<b>01/09/2021</b>	At the latest on 1 September, the Minister may review the required volume of the strategic reserve based on an updated analysis of the system operator and advice from the General Direction Energy, by means of a ministerial decree deliberated in the Council of Ministers. In the event that the volume of the strategic reserve is reduced to zero, the tendering procedure will come to an end.	Minister ⇒ ELIA + CREG
<b>&lt;= 13/09/2021</b>	Techno-economical selection based on the manifest reasonable offers found by the CREG. A contract will be <b>awarded</b> to the reasonable and withheld offers*. From this point on the manifestly unreasonable offers fall outside of the scope of this Procedure. Fifteen days after the award, the contracts will be concluded for the awarded offers.	ELIA ⇒ Minister, General Direction Energy + CREG  (*Elia ⇒ Awarded SDR and SGR Suppliers)
<b>&lt;= 15/09/2021</b>	If the awarded selection is insufficient to reach the required volume, ELIA will prepare a report with regard to the necessary additional volume.	ELIA ⇒ Minister, General Direction Energy + CREG
<b>&lt;=29/09/2021</b>  <b>&lt;= the latest 10 Work Days after the report</b>	Techno-economical selection for the missing volume based on the candidate SGR and SDR Suppliers whose offers was considered manifest unreasonable by the CREG.	General Direction Energy => Minister
<b>&lt; 31/10/2021</b>	The Minister imposes prices and volumes for the manifestly unreasonable offers. The modalities of this procedure and applicable contracts apply by operation of law.	Minister ⇒ Awarded SDR and SGR Suppliers

## 4.2

### Consulting stakeholders

Art. 7quinquies of the Electricity Law stipulates that ELIA determines (and publishes) the Procedure for Constitution of Strategic Reserve following consultation. ELIA created a dedicated task force within its Users' Group (which also comprises CREG representatives) that specifically deals with the implementation of strategic reserve and the tender to be carried out in order to:

- **inform** market parties and stakeholders of all relevant aspects associated with the implementation of strategic reserve;
- **consult** market parties and stakeholders, particularly regarding the tendering procedure (including all relevant elements concerning this procedure such as selection criteria, tender rules, etc.) and the Functioning Rules (including product requirements, detection, activation, etc.) for strategic reserve (the latter is to be approved by CREG on proposition of ELIA).

## 4.3

All documentation regarding these consultations can be found here:

<https://www.elia.be/en/public-consultation>

### Entry into force and duration

The present Procedure for Constitution of Strategic Reserve will be applied at the latest at the start of the tender procedure organised over the course of 2021. This

tender procedure starts at the latest one month after the instruction of the Minister to ELIA to constitute strategic reserve.

**Please note:** The Procedure for Constitution of Strategic Reserve will enter into force at the latest on this date if and only if the Minister's decision relates to the constitution of a strategic reserve for the Winter Period 2021-2022.

### **Hierarchy of documents**

Without prejudice to the principles of the legal hierarchy and without prejudice to the application of the relevant laws and regulations, including those regarding liberalisation of the electricity market and strategic reserve in particular, the hierarchy of documents is determined as described below.

#### **4.4**

If there are any difficulties in interpreting or any contradictions between the constitutive elements of the relevant laws and regulations, the Functioning Rules, the Procedure for Constitution of Strategic Reserve, the SGR/SDR Contract or the General Terms & Conditions, each document shall take precedence over the following one in the following order:

1. To prevent any doubt, the relevant laws and regulations, including the Functioning Rules<sup>7</sup>, will always prevail.
2. This Procedure for Constitution of Strategic Reserve.
3. The SGR/SDR Contract(s) signed by ELIA and the SDR/SGR Supplier(s).
4. The General Terms & Conditions (i.e. for strategic reserve).
5. If applicable, the CIPU Contract or Black Start contract signed by ELIA and the CIPU contract holder or the Black Start contract holder respectively.

#### **4.5**

### **Ministerial Decree on the determination of volumes**

#### **4.5.1**

#### **Initial required volume**

In accordance with art.7<sup>quarter</sup> of the Electricity Law, the Minister may instruct, by means of Ministerial Decree, ELIA, no later than 15 January 2021, to constitute a strategic reserve for a period of one year starting on the first day of the following Winter Period and sets the level of this reserve in MW.

**4.5.2** This document was therefore submitted for public consultation in anticipation of a possible instruction by the Minister to constitute a volume of strategic reserve.

#### **Possible revision volume**

Since the security of supply situation may change in the period between January 15 and the start of the following Winter Period, it is possible that the requested volume of the strategic reserve no longer corresponds with the criteria referred to in art.7<sup>bis</sup>, § 2 of the Electricity Law. The Electricity Law therefore provides, in accordance with art.7<sup>quarter</sup>, the possibility for the Minister, by 1 September of each year, on the basis of an updated analysis of ELIA and advice from the General Direction Energy, by means of a Ministerial Decree deliberated in the Council of Ministers, to revise the required and fixed volume of the strategic reserve.

---

<sup>7</sup> The Functioning Rules are proposed by ELIA and submitted to CREG for approval in line with art. 7<sup>septies</sup> §1 and 2 of the Electricity Law.



## Delivery Points

5

**Under art.7sexies, §3 of the Electricity Act, ELIA can only make a technological selection of the non-manifestly unreasonable offers after 1 September, i.e. the latest date on which the Minister may revise the volume of the strategic reserve. As a consequence, this selection is not yet known on the deadline for ordering a Submeter option (see 5.1). Given that an administrative sanction will be applied if the actual commissioning of the submeter(s) is not on time, Elia will have to ask all the SDR candidates to make all necessary preparations at their own risk or, should the SDR candidates not make all such preparations, to certify only delivery points already equipped to do the service.**

It is stipulated that a Delivery Point: Is a point, located on the electricity grid from where the SDR Service can be delivered.

It may be:

- a. An Access Point connected to the ELIA Grid;
- b. An Access Point connected to the DSO Grid;
- c. A point within the electrical facilities of a grid user downstream of an Access Point connected to the ELIA Grid (hereafter referred to as 'TSO Submetering Delivery Point');
- d. A point in a CDS connected to the ELIA Grid;
- e. A point within the electrical facilities of a grid user downstream of an Access Point connected to the DSO Grid (hereafter referred to as 'DSO Submetering Delivery Point').

Every Delivery Point must be associated with one or more meter(s) allowing ELIA to control and measure the delivery of the SDR Service. In cases a or b, the metering associated with the Delivery Point is given by Headmeters. Specific requirements related to cases c, d and e are described in the chapters 5.1, 5.2 and 5.3 below.

The Transfer of Energy Rules apply to each SDR Delivery Point whose average annual net offtake is positive<sup>8</sup>. In other words, an SDR supplier will only be able to include these points in his pool provided that:

- ELIA received a Grid User Declaration that contains the elements listed in art. 7.1 of the Energy Transfer Rules;
- ELIA received proof of the financial compensation agreement, in accordance with art. 7.1 of the Energy Transfer Rules, between the SDR Supplier and the supplier of the relevant Delivery Point;
- The SDR Supplier has drawn up a bank guarantee prior to the entry into force of the SDR Contract, in accordance with the provisions of chapter IV of the Energy Transfer Regulations and related articles of the decision (B) 1677 of the CREG, for all concerned Delivery Points;
- Each Delivery Point with correct information is included in the applicable appendix of the SDR DROP-BY and / or DROP-TO contract.
- BRP-FSP agreement
- In the case of an Access Point connected to the DNB's Net, ELIA must receive a copy of the signed Grid User Declaration.

<sup>8</sup> ELIA is responsible for this calculation, as described in art. 10.2 of the Rules for the Transfer of Energy..

The moment of delivery for the above documents will be specified in both the present document and in the SDR Contract.

## Requirements for TSO Submetering Delivery Points

5.1

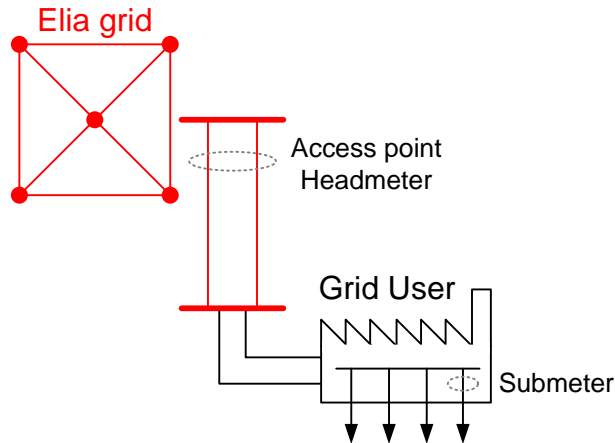

TSO Submetering Delivery Points will be measured by a Submetering facility.

### Technical requirements for TSO Submetering Delivery Points

5.1.1 Submeters for sites connected to the ELIA Grid must comply with the minimum technical requirements described in the 'General Technical Requirements of the Submetering Solutions', which is available on the ELIA website:

<https://www.elia.be/en/electricity-market-and-system/document-library>

In the case of portfolios containing Delivery Points with Submetering, it should be noted that the service cannot be delivered with more than 4 Submeters per MW offered.

5.1.2

### Providing ELIA with Submetering data for TSO Submetering Delivery Points

ELIA's metering data management system must be able to acquire the quarter-hour values of active power measured by a Submeter. This must be done in one of the following ways:

- Option 1: the Submeter fully complies with ELIA's metering standards (see. 'General Technical Requirements of the Submetering Solutions') and is therefore able to directly communicate with ELIA's metering data management system.
- Option 2: the private Submeter is connected to a Data Logger (compliant with ELIA standards, see 'General Technical Requirements of the Submetering Solutions') that passes on the measured values to ELIA's metering data management system through a communication protocol known by ELIA.
- Option 3: the private Submeter is connected to a GSM modem (compliant with ELIA standards, see 'General Technical Requirements of the Submetering Solutions') that passes on the measured values to ELIA's metering data management system through a communication protocol known by ELIA.

### **Compliance of Submetering facilities at sites connected to the ELIA Grid**

To ensure that the Submetering facilities comply with all requirements mentioned in §5.1.1 and §5.1.2 and to gather all the technical information required for commissioning the Submeters and/or the communication with the ELIA metering data management system, SDR Candidates are obliged to provide a range of **5.1.3** technical information about their Submetering facility prior to commissioning (see also §7.6.2). Based on the technical information provided by the SDR Candidate, ELIA will decide whether or not to validate the compliance of the Submetering facility.

The list of technical information to be supplied to ELIA ('Submetering Technical\_Information\_Checklist' document) will be available on ELIA's website at the following link:

<https://www.elia.be/en/electricity-market-and-system/document-library>

This document must be completed and returned to ELIA by 04 June 2021 at the latest (see table below).

Notwithstanding the above, when SDR Candidates submit a certification request for a TSO Submetering Delivery Point, they shall already be obliged to supply a single-line diagram of the site showing the Submeter(s) as well as, where relevant, the corresponding metering equation. In addition, a request is made to indicate the existing Emergency Generator(s), in case they would like to be included in the SDR Reference Power.

Communication with the ELIA metering data management system must be effective by 15 October 2021. It shall be commissioned by ELIA. In order for ELIA to guarantee compliance with deadlines, SDR Candidates must submit an offer request for one of the permitted options (see §5.1.2) by 04 June 2021. Failure to comply with the commissioning deadline will result in an administrative penalty. This penalty is defined as

Reservation price (in €/MW/h) \* 0.3 \* contracted power \* 24 hours \* 7

and will be imposed for each week of the Winter Period in which the conditions are not fulfilled on the first day (Monday) of that week.

The following deadlines must be met for TSO Submetering Delivery Points:

- **<=02/04/2021**: Submission (with the certification request) of the single-line diagram and, where relevant, the metering equation.
- **<=14/05/2021**: Deadline for submission of SDR offers.
- **<=04/06/2021**: Deadline for submission of an offer request (i.e. choice of option for communication of metering data to ELIA) to ELIA. After this date, ELIA will no longer be able to guarantee commissioning by 15/10/2021.
- **<=13/08/2021**: Deadline for actually ordering a Submetering option (see 5.1.2).
- **<=15/10/2021**: Deadline for Submeter commissioning. After this date, an administrative penalty will be applied to the SDR Supplier.

The technical information to be supplied to ELIA is shown in the following table:

Metering data used for certification	Technical information to be supplied to ELIA				
	Single-line diagram <sup>(1)</sup>	Metering equation <sup>(2)</sup>	Technical information <sup>(3)</sup>	Site plan	Accuracy check or calibration report <sup>(4)</sup>
No past Submetering data or past data < 6 weeks (Winter Period) <b>=&gt; A Submetering solution must be ordered (5.1.2)</b>	with the certification request	with the certification request	< 04/06	< 04/06	< 04/06
Submetering data exists (> 6 weeks during Winter Period) but no communication with the ELIA system <b>=&gt; A Submetering solution must be ordered (5.1.2)</b>	with the certification request	with the certification request	< 04/06	< 04/06	< 04/06
Submetering data exist (> 6 weeks during Winter Period) and communication with the ELIA system is operational=> <b>A Submetering solution does not need to be ordered (5.1.2)</b>	ELIA will check whether the information it has is complete.				

<sup>(1)</sup> with location of meter(s)

<sup>(2)</sup> where relevant

<sup>(3)</sup> The required technical information is available in the document "Submetering Technical Information Checklist" on ELIA's website: <https://www.elia.be/en/electricity-market-and-system/document-library>

<sup>(4)</sup> at least the planned date of the check must be communicated (before commissioning of communication with ELIA)

## 5.2 Requirements for Delivery Points within a Closed Distribution System connected to the ELIA Grid

Delivery Points in a Closed Distribution System connected to the ELIA Grid can participate in the SDR Service and must respect the following specific conditions:

- The **metering facilities** associated with Delivery Points within a Closed Distribution System must (already) be used by the CDS Operator in relation to their invoicing obligations regarding their CDS Access Points. These metering facilities must enable 1/4-hourly measurement of active energy and fulfil at least the technical requirements specified in the applicable Grid Code; the technical information contained in the table below must also be provided to ELIA.
- **In case of new CDS metering installations:** the installation must be completed and metering data exchange must be operational at latest at 15/10/2021 so that ELIA can dispose of data with which to perform its Baselineing starting from 1/11/2021. Failure to comply with this deadline will result in an administrative penalty. This penalty is defined as:

Reservation price (in €/MW/h) \* 0.3 \* contracted power \* 24 hours \* 7

and will be imposed for each week of the Winter Period on which the conditions are not fulfilled on the first day (Monday) of that week.

- **Data exchange:** As the CDS Operator already uses the metering data of the metering facilities within the CDS for invoicing purposes, the CDS Operator will send the metering data directly to ELIA using the data exchange formats as specified in his cooperation agreement with ELIA (see next point). A description of the permitted data exchange formats is available on the ELIA website.

- A **cooperation agreement between ELIA and the CDS Operator**: This agreement typically lays down the details of the metering data exchange between ELIA and the CDS Operator. It must be signed and executed by both parties **before** the start of the SDR Contract<sup>9</sup>.

The SDR Candidate must enclose with their certification request – **at the latest on 02 April 2021** – a **CDS Operator declaration**<sup>10</sup> in which the CDS Operator agrees that the CDS grid user can participate in the SDR Service and the CDS Operator commits to signing the cooperation agreement with ELIA under the condition that the SDR Candidate is awarded an SDR Contract.

The technical information to be supplied to ELIA is shown in the following table:

Technical information to be supplied to ELIA			
Single-line diagram <sup>(1)</sup>	Metering equation <sup>(2)</sup>	Technical information <sup>(3)</sup>	Accuracy check or calibration report
with the certification request	with the certification request	< 04/06	not mandatory
If the Delivery Points have already been selected following an earlier Call for Tender, ELIA will check whether the information it has is complete.			

<sup>(1)</sup> with location of meter(s)

<sup>(2)</sup> where relevant

<sup>(3)</sup> The required technical information is available in the document "CDS Metering Technical Information Checklist" on ELIA's website: <https://www.elia.be/en/electricity-market-and-system/document-library>

## 5.3 Requirements for DSO Submetering Delivery Points

### 5.3.1 Technical requirements for DSO Submetering Delivery Points

The Submeters of sites connected to the Distribution Grid must comply with the **5.3.2** minimum technical requirements formulated by the DSOs<sup>11</sup>.

#### Providing ELIA with Submetering data for DSO Submetering Delivery Points

**5.3.3** The relevant DSO will provide ELIA with the data measured by a Submeter situated on a site connected to the DSO grid.

#### Compliance of Submetering facilities at sites connected to the DSO grid

The technical compliance of Submetering facilities at sites connected to the DSO grid will be certified by the concerned DSO.

The commissioning of the Submetering facilities/facilities must be effective before 15/10/2021. Failure to comply with this deadline will result in an administrative penalty. This penalty is defined as

$$\text{Reservation price (in €/MW/h)} * 0.3 * \text{contracted power} * 24 \text{ hours} * 7$$

<sup>9</sup> A template agreement can be obtained by sending an e-mail to Contracting\_SR@elia.be

<sup>10</sup> Owing to short deadlines, e-mail confirmation sent by CDS Operator and SDR Candidate to Contracting\_SR@elia.be shall suffice in this tendering procedure.

<sup>11</sup> Available at:

[http://www.synergrid.be/download.cfm?fileId=C8\\_02\\_SpecifiekeMeters\\_20161129\\_FINAAL.pdf](http://www.synergrid.be/download.cfm?fileId=C8_02_SpecifiekeMeters_20161129_FINAAL.pdf)

and will be imposed for each week of the Winter Period on which the conditions are not fulfilled on the first day (Monday) of that week.

## Shared Connection Points

Sites with an out of the market SGR Unit under an Access Point can still host with a separate asset (e.g. wind turbine or diesel generator) for ancillary services and/or supply of electricity. To do this a configuration with a second Access Point, with a Headmeter, for the available asset has to be set up.

6

### Simplified representation

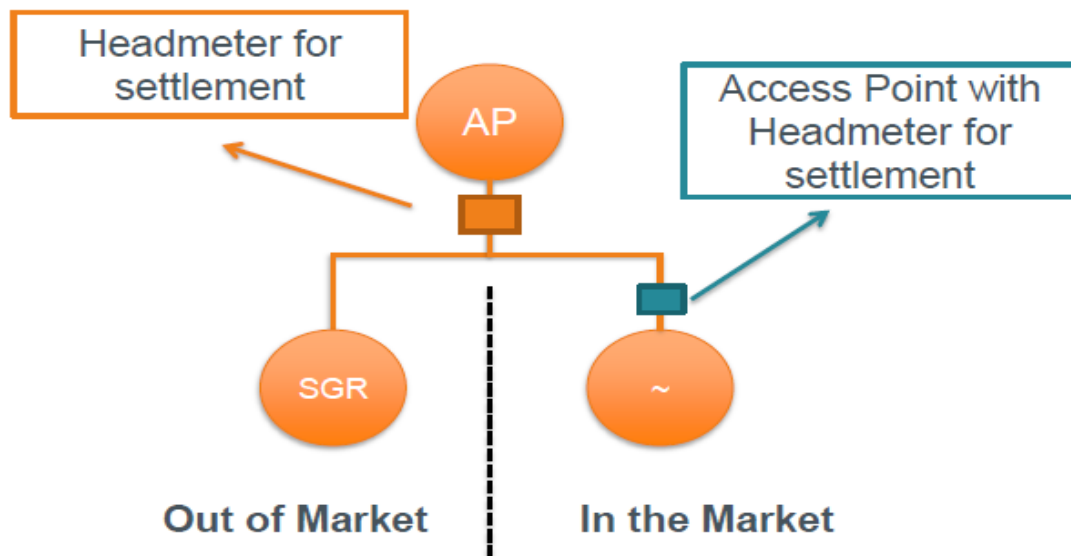

Figure 2: Simplified representation shared connection point

6.1

### From SGR to Shared Connection

An SGR Power Plant contains (a) unit(s), in accordance with art. 7 quinquies § 2, 2° to 4° of the Electricity law, that are considered "out-of-the-market". This means that this/these unit(s) is/are therefore stationary and ready to be started at any time during the Winter period(s) for which they were contracted in order to safeguard the security of supply. Consequently, both at the start or during the time of the SGR contract, for (each of) the unit(s) the SGR supplier may not (i) have any contracts for the selling of electricity, with the exception of the contracts referred to in art 2.2. of the SGR contract, or (ii) offer any type of support services, with the exception of the Black-Start Service under the conditions set out in the contract for the Black-Start service.

6.2 Should the same Power Plant, however, host a separate asset (Demand-Response, storage, or generating unit), then this asset could, should all requirements listed in art. 6.2 be met, be classified as in-the-market and therefore offer ancillary and/or be used for selling electricity.

### Requirements for a shared Connection Point

A shared connection point connected to the ELIA Grid can participate in ancillary services and/or supply of electricity but must respect the following specific conditions:

1. Autonomy

In case of an activation of either service, both the Unit(s) under SGR-Contract as the in-the-market asset have to be able to operate completely independently. An activation of the Service must have an overall effect of either reducing net offtake or increasing net injection at the level of the Access Point compared to usual practice.

## 2. Separate Access Point

A separate Access Point, with Headmeter, has to be foreseen for the separate asset (see Figure 1), enabling the settlement procedure for ancillary services and supply of electricity.

## 3. No Transfer of Costs

Considering that both have to be able to generate active power independently from each other and each unit has its own Headmeter, there may also not be any transfers of costs towards the SGR contract or vice versa. In order to avoid transfers a specific "Shared Connection Contract" has to be signed.

# Stages of the tendering procedure

- 7** Pursuant to art. 7 quinquies of the Electricity Law, the tendering procedure that ELIA is instructed to organise, must collect offers based on objective, transparent, non-discriminatory and on market rules based processes.

The tendering procedure aims at collecting offers from market participants offering capacity in order to face potential security of supply problems.

It should be noted that CREG could:

- 1) Deem the prices of the offers unreasonable, in which case the Minister may, by means of a Ministerial Decree deliberated in the Council of Ministers, impose prices and volumes;
- 2) Apply administrative fines to market participants that do not respect their legal obligation to submit an offer.

Both 1) and 2) are beyond the scope of this procedure.

- 7.1** ELIA will organise a negotiated procedure with publication.

### 7.1.1

## Call for Candidates

### Contract Notice and Admission process

Prior to the Call for Tender, ELIA will publish a Contract Notice inviting parties to declare their interest in participating in the Call for Tender for strategic reserve by sending an application file.

- The Call for Candidates will be announced by means of a **Contract Notice** sent for publication at the latest on 15 February 2021 on the Tenders Electronic Daily website (<http://ted.europa.eu/>).
- In order to be valid, an application file must be sent via registered letter or carrier to following address:
  - ELIA Transmission Belgium -Arno Motté  
20 Boulevard de l'Empereur  
B - 1000 Brussels
  - Each application file must consist of an original paper version and an electronic copy and must be sent to [arno.motté@elia.be](mailto:arno.motté@elia.be) and [contracting\\_SR@elia.be](mailto:contracting_SR@elia.be).

- If there is a discrepancy between the electronic version and the printed version, the original paper copy shall prevail.
  - The SGR or SDR Candidate shall state clearly which information is confidential and/or relates to technical and commercial secrets.
- Every application file must comprise all information required to demonstrate that the conditions listed in 7.1.2. are fulfilled.
- The application file must be written in English, French or Dutch.
- The application file must be complete and received by ELIA before 6 p.m. Central European Time (CET) on 5 March 2021.
- ELIA reserves the right to verify the information provided in the application files.

Before the Call for Tender at the latest, ELIA will electronically communicate the results of the Admission procedure to the address specified by the SGR or SDR Candidate:

- If Admission was not granted because of an unsuccessful application file, ELIA will provide reasons for the rejection.
- If an application file is granted Admission, the candidate will receive an invitation to participate in the Call for Tender.

#### **Application file for SGR and SDR Candidates**

7.1.2 ELIA will grant Admission if the application files from the SGR and SDR Candidates satisfy the following conditions for both SGR and SDR Candidates:

1. The SGR/SDR Candidate must provide a description of their intended participation in the Call for Tender. This description includes, where appropriate, the legal structure, the list of partners involved, their role and the nature of their relationship with the candidate.
2. The SGR/SDR Candidate must comply with their social security, VAT and tax obligations. Candidates must submit either a sworn statement<sup>12</sup> or a recent certificate provided by the competent authority as proof that they are complying with these obligations.
3. The SGR/SDR Candidate must declare in the same sworn statement that they are neither bankrupt, nor the subject of bankruptcy or liquidation proceedings, nor do they find themselves in a similar situation.
4. The SGR/SDR Candidate must declare in the same sworn statement that they have not been convicted of an offence concerning their professional integrity or been subject to a judgment *res judicata* for fraud, corruption, involvement in a criminal organisation or any other illegal activity detrimental to the financial interests of Belgium and other European Union Member States.
5. The SGR/SDR Candidate must provide proof of their economic and financial capacity. To this end, the SGR/SDR Candidate must submit the following documents to ELIA:

Creditsafe score: An international score from A to E. In case of a creditsafe score of D or E, the candidate will not be rejected as such but ELIA may ask for extra information and/or guarantees. ELIA can order this report and send it to the SGR/SDR Candidate if explicitly requested to do so by the SGR/SDR Candidate.

#### **Conditions for SGR Candidates only:**

1. The SGR Candidate must provide the list of (Candidate) SGR Power Plant(s) that are eligible to participate, taking into account the fact that

---

<sup>12</sup> In case the sworn statement was provided to ELIA for another tender/qualification, a copy of this sworn statement is sufficient, as long as the signature dates less than 2 years from the start date of Call for Tender.



the proposed (Candidate) SGR Power Plant(s) must comply with the Certification of SGR Power Plant(s) criteria as listed in Chapter 7.2.1. In accordance with article *7quinquies* §3 of the Electricity Law, SGR Candidates, whose production power plant(s) has/have a net developable capacity of at least 25 MW, are obliged to submit at least one offer for the Power Plant(s) concerned, which is the complete capacity of the Power Plant as referred to in the Electricity Law.

2. The SGR Candidate must provide technical specifications for each (Candidate) SGR Power Plant as specified in the Contract Notice. These technical specifications will be based on elements of the Annex 1 of the CIPU Contract and elements related to the SGR Contract.
3. If the Candidate SGR Power Plant is (was) included in a CIPU Contract, the parameters submitted in connection with SGR may differ from those declared in connection with the CIPU Contract, which may also be updated accordingly if necessary. In any case, all data must be justifiable and provable.
4. All of the requested information must be included in the SGR Candidate's application file, which must be submitted no later than the deadline for the Call for Candidates on 05/3/2021.

Next to this, additional information may be requested by ELIA to the SGR-Candidate about the technical specifications as a part of the (Candidate) SGR Production Unit Certification process. The SGR Candidate will answer to this request with a sufficient detail level and within a reasonable deadline.

5. Ultimately offered volumes must be divisible, in accordance with Article *7quinquies*, §3*bis* of the Electricity Law, taking into account the technical characteristics of the offered capacity. There will mainly look at the configurations that were technically possible at the time of the announcement to close.
6. The SGR Candidate has to pass the Admission Procedure before the start of the Call for Tender in accordance with chapter 7.2.1. It is possible that this condition has not yet been met at the time when the results of the Admission Procedure are communicated. In such a case, the Candidate who meets all other applicable conditions under Chapter 7.1.1 will be admitted to the further course of the procedure, unless the Candidate in question is not yet admitted on the date on which the Call for Tender is launched, in accordance with chapter 7.2.1.
7. A candidate SGR Power Plant can be excluded if it does not meet the stipulated conditions included in the Functioning Rules.

Additionally ELIA may ask SGR Candidates for additional information regarding these technical specifications as part of the (Candidate) SGR Power Plant certification process. The SGR Candidate shall provide a reasonable level of detail and respond within a reasonable timeframe.

**Conditions for SDR Candidates only:**

1. Each SDR Candidate must provide a preliminary list of the Delivery Point(s) that he intends to propose in his offer during the Call for Tender taking into account the fact that the proposed Delivery Point(s) must correspond to

one of the 5 categories as mentioned the definition of Delivery Point in chapter 5 "Delivery Points" and be located in the Belgian Control Area. In addition, the SDR Candidates must check whether each Delivery Point meets the conditions set out by the Transfer of Energy Regulations, as described at the start of Chapter 5.

2. The SDR Candidate must have passed the Admission Procedure before the start of the Call for Tender in accordance with chapter 7.2.2. It is possible that this condition has not yet been met at the time when the results of the Admission Procedure are communicated. In such a case, the Candidate who meets all other applicable conditions under Chapter 7.1.2 will be admitted to the further course of the procedure, unless the Candidate in question is not yet admitted on the date on which the Call for Tender is launched, in accordance with chapter 7.2.2.
3. A candidate SDR Unit can be excluded if it does not meet the stipulated conditions included in the Functioning Rules.

**Important disclaimer:** The assets in the SDR Unit used to provide the SDR Service with the SDR Reference Power should reduce electricity consumption (in MW) by changing, stopping or slowing down an energy-consuming process, including by injection of Emergency Generators, without relying on increased generation of electrical energy.

## Certification

### Certification of SGR Power Plant(s)

During the call for Tender, only offers submitted by SGR Candidates that have successfully passed the Admission procedure **and** are based on certified SGR Power Plants will be accepted. Candidate SGR Power Plants can receive an SGR certification **7.2** no later than the start date of the Call for Tender as long as they fall into one of the following categories:

**7.2.1**

1. Any Candidate SGR Power Plant which has issued a notice of definitive inoperability based on article 4bis §1 and which, at the time that ELIA receives the instruction for the constitution of a strategic reserve from the Minister, delivers strategic reserve;
2. Any Candidate SGR Power Plant that announced a closure according to art. 4bis of the Electricity Law before the Minister's decision to constitute a strategic reserve and for which the closure is not yet effective but will take place prior to the start of the Winter Period referred to in the procedure;
3. Any Candidate SGR Power Plant that announced a temporary closure according to art. 4bis of the Electricity Law for which the closure is effective.

Operators belonging to one of these three categories, as identified in art. 7 quinquies, §2, 2° to 4°) of the Electricity Law and of which the Production Unit has a net developable capacity of at least 25 MW, are obliged to submit at least one offer for the entire capacity of each Configuration of the Candidate SGR Power Plant. The volumes offered must be divisible and offer every possible configuration that was technically possible at the time of the announcement to close.

In addition, a certified SGR Power Plant must consist of a set of Production Units able to generate electricity without relying on one or more Production Units still active on the market.

A SGR Power Plant that is awarded an SGR Contract will not be allowed to participate in any ancillary services tender, with the exception of Black Start, for which the details of participation will be outlined in the related Black Start tendering procedure.

In addition, SGR Candidates are asked to offer the volume, of every configuration of the Power plant, that can be developed at 15°C and 1 atmosphere (atm) and that can be injected into the grid at the SGR Power Plant's Access Point (in other words the facility's Pmax Ref of every Configuration of the Power Plant). To do this, the SGR Candidate must be able to justify, no later than the start date of the Call for Tender, the power that the SGR Power Plant can deliver at that plant's grid Access Point<sup>13</sup> at 15°C and 1 atm based on selected past data from the past two years. In practice, the SGR Candidate shall indicate the dates on which the Pmax Ref was achieved, where necessary, corrected<sup>14</sup> and standardised at a temperature of 15°C and 1 atm. To this end, the SGR Candidate must supply the curve or the function indicating the relationship between the Pmax Ref and the outside temperature<sup>15</sup>.

The power offered by the SGR Power Plant, which corresponds to Pmax Ref, is firm and binding and must be attainable at any time during a Simulation Test and activation, otherwise a penalty will be imposed for the missing power.

---

<sup>13</sup> As determined by the meter at the Access Point in question.

<sup>14</sup> Based on curves showing the variation of Power as a function of temperature.

<sup>15</sup> If it is not possible to supply representative metering data (e.g. because investments are needed before 1/11 and have not been finalised at the time the certification request is submitted), a sufficiently justified adjustment of the metering data may also be accepted.

### Certification of SDR Reference Power

During the Call for Tender, only offers submitted by SDR Candidates that have been granted Admission **and** respect the “certified maximum SDR Reference Power” (described later in this section) for a given (combination of) Delivery Point(s), while maintaining SL or UM values for each Delivery Point which are less than or equal to the values for which the (combination of) Delivery Point(s) have been certified, will **7.2.2** be accepted.

Delivery Points that, since 1<sup>st</sup> November 2021, do not meet the above described conditions will be excluded from the certified power and have to be replaced by one or more Delivery Points under the conditions described in the Procedure for Constitution (see Chapter 5).

The frequency of such changes shall be limited to 2 times a year, whereby a year is understood as the period from 1 November year Y to 31 October year Y+1.

Requests for Certification of a maximum SDR Reference Power must satisfy the practicalities and criteria below.

#### Metering data for Certification of SDR Reference Power

In order to issue a certified maximum SDR Reference Power, ELIA will base **7.2.2.1** its analysis on historical metering data of the three most recent Winter Periods. In case the Delivery Point did not exist during these whole time periods, ELIA will use metering data of at least the most recent Winter Period. This rule is applicable for all Delivery Points excluding Delivery Points connected to the ELIA Grid.

A Certification request of SDR Reference Power for a given combination of Delivery points will be based on the following metering data:

- Validated Headmetering of the ELIA Headmeter(s)<sup>16</sup> for Delivery Points connected to the ELIA Grid;
- Validated Headmetering of the DSO Headmeter(s) or Submeter<sup>17</sup> for Delivery Points connected to the Distribution Grid or DSO Submetering Delivery Points;
- Validated Submetering of the **existing** Submeter(s)<sup>18</sup> for TSO Submeter Delivery Points under the following condition:
  - Submetering Technical Information Checklist at the latest on 02 April 2021 (see also 5.1.3);
- Validated metering of the **existing** metering facilities for Delivery Points within a CDS under the following conditions:
  - CDS Metering Technical Information Checklist at the latest on 02 April 2021;
  - CDS Operator declaration at the latest on 02 April 2021 (see 5.2).

A profile will be applied in case<sup>19</sup>:

---

<sup>16</sup> ELIA already possesses Headmetering of its own Grid. SDR Candidates can request this information through the grid user or from ELIA after a signed grid user declaration that grants access to meter data.

<sup>17</sup> The concerned DSO will provide ELIA with the Headmetering of the Delivery Point(s). SDR Candidates must consult the DSO Concerned for process to obtain the Headmetering.

<sup>18</sup> All metering data available during the period 1/11/2018-31/03/2019; 1/11/2019-31/03/2020; 01/11/2020-28/02/2021 will be used.

<sup>19</sup> Nevertheless, if the available past metering data cover less than one Winter Period but more than six weeks within the Winter Period, SDR Candidates are invited to provide those metering data as well. ELIA will be fair when deciding whether the data will be taken into account for the certification.

- a Submeter is installed after 02 April 2021;
- Submeter's past metering data are available for less than one Winter Period;
- There is no valid proof of Submeter compliance before 02 April 2021.

A profile is established on the basis of:

- 1) either relevant past (and thus existing) data such as metering data from the process or another similar process (correctly scaled with the installed power of those processes)
- 2) or "on/off" values related to the process that will be metered by the Submeter multiplied by the installed power of that process x 0.75.

In case there are no relevant past data or "on/off" values, the profile will be established by multiplying the Headmetering at the corresponding Access Point by a pro rata ratio (= declared average Offtake of the Delivery Point over three Winter Periods divided by the average Offtake over three Winter Periods at the corresponding Access Point), as also mentioned by ELIA in the document "SDR Certification Guidelines" that is available on ELIA's website. All conditions such as the installation of the Submeter and provision of the Submeter Technical Information Checklist must be fulfilled prior to the date of "Commissioning" (see 7.6). Otherwise rules and administrative penalties as stipulated in the SDR Contract shall apply.

In addition, for Delivery Points with Submetering, as described in Chapter 5.1.3, ELIA requires certain technical information to be supplied to it with the certification request. If this information is not provided, the Delivery Points with Submetering will not be included in the certification.

#### 7.2.2.2

##### **Certification request practicalities**

A valid request for Certification of SDR Reference Power must be sent by 02 April 2021 6 p.m. CET to [Contracting\\_SR@elia.be](mailto:Contracting_SR@elia.be) and must contain the following information for each (combination of) Delivery Point(s) (SDR Unit) submitted for Certification:

- List of Delivery Point combinations for the specific request;
- For each Delivery Point combination :
  - Type of Product (SDR DROP-TO or SDR DROP-BY) offered;
- For each Delivery Point:
  - In case of a SDR DROP-TO, the Shedding Limit SDR,  $SL_{DR}$  (which does not take into account the possible injections of Emergency Generators ); for the certification procedure only, the value used will be  $\max(0 ; SL_{SDR})$ ;
  - In case of a SDR DROP-TO, the Unsheddable Margin SDR,  $UM_{DR}$  (which does not take into account the possible injections of Emergency Generators); for the certification procedure only, the value used will be  $\max(0 ; UM_{SDR})$ ;
  - The capacity, i.e.  $R_{refEG}$ , of the Emergency Generator(s) present that can operate in island mode operation and meet the conditions;
  - $R_{refEG}$ , the maximal SDR power in delivered MW by Emergency Generators, is the sum of  $R_{refEGi}$ , per Delivery Point (i).

- $R_{refDR}$ , the maximal SDR power delivered in MW by offtake reduction (which does not take into account the possible injections of Emergency Generators), is the sum of  $R_{refDRi}$ , per Delivery Point (i).
- Signed Grid User Declaration :
  - confirming exclusivity regarding the participation of the grid user's Delivery Point in the SDR Candidate's SDR Unit;
  - granting ELIA access to the Delivery Point's (past) metering data;
  - and containing the listed elements, in accordance with art. 7.1 of the Energy Transfer Rules.
- Sufficient technical proof of the flexibility offered. This must contain at least the following for each Delivery Point in the proposed SDR Unit:
  - A sworn statement of the SDR Candidate that the SDR Service at the Delivery Point will not be offered by means of CHPs or other production units (with the exception of the by ELIA certified Emergency Generators);
  - A description of the industrial processes by which flexibility will be offered;
  - A description of the Delivery Point's ability to contribute to the SDR delivery, describing the electrical connection of the main facilities downstream of the Access Point and the connection of the flexible process to the site's other facilities.
- Justified explanation if certain periods are to be excluded from past metering data;
- Justified explanation if certain periods have to be corrected due to significant developments foreseen in the total consumption profile, such as the recent introduction of a new industrial process or the deconstruction of an old industrial process. ELIA and the SDR Candidate will consult each other in order to determine how metering data will be corrected. In case of disagreement on the correction to apply to the metering data, ELIA will take the final decision and will motivate it.

As described above, for all delivery points SDR candidates must submit validated metering data for the periods 1/11/2018-31/03/2019, 1/11/2019-31/03/2020 and 01/11/2020-28/02/2021. In cases where such data is not available, SDR candidates must submit all other data, mentioned here above, that is required by ELIA to perform the certification.

Suppliers must submit the documents, metering data and/or justifications as described in the paragraph above " Metering data for Certification of SDR Reference Power" for Delivery Points within a CDS or TSO Submetering or DSO Submetering Delivery Points.

For Delivery Points that are Access Points connected to the Distribution Grid or DSO Submetering Delivery Points, SDR Candidates<sup>20</sup> must have obtained a DSO approval specifying the conditions under which the respective Access

---

<sup>20</sup> For more information, please consult the document C8 / 01 on the Synergrid website (only in Dutch or French available): <http://www.synergrid.be/index.cfm?PageID=16832#>

Point(s) can participate in the SDR Service. The DSO will provide ELIA with the maximum power values for the Delivery Point(s) subject to the certification.

At the latest by 23 April 2021, ELIA will send the certification of maximum SDR Reference Power for each combination of Delivery Points (including Emergency Generators) to the e-mail address specified by the SDR Candidate. This "maximum Certified SDR Reference Power" is calculated by ELIA as the sum of the maximum share of Emergency Generator(s) ( $R_{refEG}$ ) and the maximum capacity reduction ( $R_{refDR}$ ).

ELIA will provide justification for rejecting any requests for Certification of SDR Reference Power. An SDR Candidate is allowed to submit a maximum of 20 requests for Certification of maximum SDR Reference Power. Although a Delivery Point can be part of several requests for Certification of SDR Reference Power for one SDR Candidate, a Delivery Point can only be part of one selected offer. As such, ELIA may restrict the 'may not be combined with' column on the bidding sheet to certain offers depending on the request for the Certification of SDR Reference Power (see 7.3.3.2).

#### **Certification of Emergency Generators**

7.2.2.3 In accordance with art.7<sup>quinquies</sup> §1<sup>bis</sup>, offers for the participation of Emergency Generator(s), which can operate in island mode operation, in the strategic reserve are allowed.

On the one hand to ensure that the Emergency Generator(s) meet the following requirements and to collect the necessary technical information, the SDR Candidate is obliged to submit a number of (technical) documents from its Emergency Generator(s) prior to the certification.

Offered Emergency Generator(s) must meet the following requirements in order to be included in the certification process:

- have a nominal capacity that does not exceed 110% of the maximum historical consumption capacity of the site (last 3 years);
- operate no more than 5 min / month while synchronized with the grid (excluding the testing of the emergency power groups);
- the generators must be able to operate independently if the network to which it is connected fails;
- not be installed for activities other than the electricity supply of this site or to guarantee a part thereof, in case the electricity supply from the network to which it is connected fails for this site or part thereof;
- not participate in ancillary services or energy market.

These requirements will have to be included in a sworn statement, which will have to be signed and submitted to Elia in the context of the application for certification.

In addition to the required sworn statement, the technical sheet of the Emergency Generator(s) must also be added, from which at least the reference power of the Emergency Generator(s) can be derived, i.e.  $R_{refEG}$ .

7.2.2.4 As already indicated in art.5.1.3 a single-line diagram must also be presented on which the Emergency Generator(s) is/are indicated. Optionally, test certificates can be added.

Furthermore ELIA reserves the right to inspect the Emergency Generator(s) on site.

#### **Exclusivity criteria governing the combination SDR DROP-TO, SDR**

**DROP-BY and/or other ancillary services on a Delivery Point**

A Delivery Point which was since November 1, 2015 part of an offer that was made in the context of a tender by the system operator for the delivery of primary, secondary or tertiary reserve power, as defined in the market rules for the compensation of quarter-hour imbalances (available at website ELIA), cannot participate in the delivery of SDR.

**Determination of the maximum Reference Power**

7.2.2.5 The volume  $R_{ref}$  offered for a given SDR portfolio must be less than or equal to the maximum allowed SDR Reference Power determined by ELIA. This maximum permitted SDR Reference Power is calculated on the basis of the decrease of the SDR portfolio ( $R_{ref_{DR}}$ ) as well as the possible activation of Emergency Generator(s) in SDR ( $R_{ref_{EG}}$ ).

$$R_{ref_{SDR}} = R_{ref_{DR}} + R_{ref_{EG}}$$

In an initial stage, the reduction in offtake of the SDR Unit is determined ( $R_{ref_{DR}}$ ), wherefore the validated metering data for each of the last three Winter Periods (2018-2019/2019-2020 and the first four months of the Winter Period 2020-2021)<sup>21</sup> and the profiles as described in the chapter "Metering data for Certification of SDR Reference Power" are adjusted for each Delivery Point, taking into account metering data that are not representative of a normal Winter Period, if this is sufficiently justified by the SDR Candidate (owing to non-recurring maintenance for instance).

In a second stage, those data and the Shedding Limit (SDR DROP-TO) or the Unsheddable Margin SDR (SDR DROP-BY), respectively  $SL_{DR}$  and  $UM_{DR}$ , are used to calculate a maximum permitted SDR Reference Power for each certification request as the maximum value satisfying the following statistical criteria for each specified period:

The Availability Rate of  $R_{ref_{DR}}$  during the periods defined in table below during the three previous Winter Periods is higher (>) than the corresponding percentages in the table below.

---

<sup>21</sup> For compliant Submeters on the ELIA Grid, metering data from the last Winter Period are accepted to determine the maximum SDR Reference Power.



[%]	Sunday and public holidays			Saturday			Working Days					
	0;17	17;20	20;24	0;17	17;21	21;24	0;6	6;7	7;12	12;16	16;20	20;24
Hour [begin; end]												
November	40	60	40	40	60	40	40	60	75	75	85	65
December	40	60	40	40	60	40	40	60	85	85	85	65
January	40	75	40	40	85	60	40	60	85	85	85	85
February	40	60	40	40	60	60	40	60	85	75	85	85
March	40	40	40	40	40	40	40	40	55	55	85	55
Christmas Holiday 1	40	40	40	40	40	40	40	40	40	40	40	40
Christmas Holiday 2	40	40	40	40	40	40	40	40	40	40	40	40
DAM price $\geq$ 150€/MWh	85											
Applicable tariff for a positive imbalance $\geq$ 150€/MWh	85											

The availability rate of  $Rref_{DR}$  for a specified period in the table above,  $AvRate_{period}(Rref_{DR})$ , expressed in % of  $Rref_{DR}$ , is defined as the percentage  $Rref_{DR}$  which is on average available for all hours (h) during the given period ("period"). The period corresponding to the availability rate corresponds to the month, represented by the row, and the hour of each type of day (working days, Saturday, Sunday and public holidays which are legally recognized), represented by the column of the table. This average only takes into account the available power lower or equal to  $Rref_{DR}$ . It is calculated as follows:

$$AvRate_{period}(Rref_{DR}) = \frac{AvVol_{period}(Rref_{DR})}{\sum_h Rref_{DR}} * 100$$

For which  $AvVol_{period}(Rref)$  is expressed in MW determined as the sum of the available power, limited to the  $Rref$ , of each of the hours h of the given period. It is calculated as follows:

$$AvVol_{period}(Rref_{DR}) = \sum_h \min(Rref_{DR}, AvPow_{TOT}(h))$$

For which  $AvPow_{TOT}(h)$  is the power which is available in SDR unit for a certain hour h. It is equal to the sum of the available power for each of the Delivery Points i of the SDR-unit for an hour h.

The available power for each Delivery Point i for the hour h,  $AvPow_i(h)$  is defined as the quarter hour average for hour h of the difference (if positive) between the quarter hour offtake of that Delivery Point and its  $SL_{DR}$  or  $UM_{DR}$  for the four quarter hours for hour h.

$AvPow_i(h)$  is calculated as follows:

- $AvPow_i(h) = avg(\max(0, offtake_i(qh) - \max(SL_{DRi}; 0)))$  for SDR DROP-TO
- $AvPow_i(h) = avg(\max(0, offtake_i(qh) - \max(UM_{DRi}; 0)))$  for SDR DROP-BY

During all hours with a DAM price of a NEMO in Belgium  $\geq 150$  €/MWh the availability rate of  $R_{ref}$  is higher than 85%, as well as during all hours with a rate of application for a positive imbalance  $\geq 150$  €/MWh. This availability percentage is calculated according to the the same way as the availability criteria of  $R_{ref}$  for the time periods in the above table  $_{period} AvRate_{period}(R_{ref})$ , where the period now stands for all hours  $h$  where the above criteria apply in this section.

In a final phase, the sum is made of the obtained  $R_{refDR}$  in combination with the sum of the capacities of the existing and approved Emergency Generator(s),  $R_{refEG}$ .

The "maximum permitted SDR Reference Power" for Delivery Points in a Distribution Grid includes the conditions for the maximum activable capacity at this point specified by the relevant Distribution System operator(s). The  $SL_{SDR}$  and  $UM_{SDR}$  have to be mentioned in the offer of the SDR Candidate. Moreover these should satisfy the following relationships:

- $SL_{SDR} \geq SL_{DR} - R_{refEG}$
- $UM_{SDR} \geq UM_{DR} - R_{refEG}$

## 7.3 Call for Tender

### 7.3.1 Launch of Call for Tender

All SGR and SDR Candidates that have passed the Admission procedure and have been awarded a Certification are invited to participate in the Call for Tender.

ELIA will send the **Call for Tender** documents at the latest on 15 March 2021 to the e-mail addresses specified by the SGR and SDR Candidates in the application file.

SGR and SDR Candidates will receive the following documents in the Call for Tender:

- SGR/SDR Contract and General Terms & Conditions;
- Bidding instructions;
- Bidding sheets;
- Contractual data form;
- Functioning Rules including award criteria;
- An example ELIA offer for the Submeters of sites connected to the ELIA Grid;
- A document setting out ELIA's General Technical Specifications for Submeters of sites connected to the ELIA Grid, which describes the specifications which Submeters of Delivery Points connected to the ELIA grid must comply;
- A Technical Addendum for Submeters of sites connected to the ELIA Grid, which is communicated by mail along with the offer example and which describes the technical details relative to this offer.

### 7.3.2 SGR/SDR Contract

The SDR and SGR Suppliers must accept and acknowledge the importance of the requirements that ELIA must meet, according to the applicable legal and regulatory

rules, in its capacity as a transmission or local/regional transmission system operator.

ELIA and the SGR and/or SDR Suppliers commit to make all necessary efforts to take due account of these requirements. As a result, if a legal or regulatory rule, decision, opinion or requirement issued by a competent authority that rules or regulates all or part of ELIA's activities calls for the revision, amendment or termination of the SDR and/or SGR Contract, ELIA can, after consulting with the SGR and/or SDR Supplier(s), amend one or more of its conditions, or it can revise, amend or, as the case may be, terminate the SDR/SGR Contract via registered mail without having to indemnify the SGR and/or SDR Supplier for this price amendment, or revision, amendment or termination of the SDR/SGR Contract.

If the SDR and/or SGR Contract(s) can be continued by means of amendments, ELIA and the SDR and/or SDR Supplier will make all necessary efforts to find the most appropriate contractual conditions that best satisfy both the initial spirit of the SDR/SGR Contract and the competent authority's requirement.

#### **7.3.2.1 Relationship between the SGR Contract and other contracts**

SGR Candidates selected on the basis of the Admission procedure and certification criteria must be aware of the mutual relationships that will exist between the SGR Contract, the CIPU Contract (if applicable), the BRP Contract and the Access Contract. SGR Power Plant(s) must:

- Be located within the Belgian Control Area;
- The BRP responsible for this Access Point must have signed a CIPU Contract with ELIA before 1 November 2021, if not already signed.
- In case of Local Production, a new Access Point Injection/Offtake must be created:
  - The SGR Power Plant is independent in terms of access from the grid user for which it used to generate energy known as a Local Production.
  - This new Access Point of the SGR Power Plant must be referenced in Appendix 2 of a valid Access Contract to allow the SGR Supplier to appoint an access holder as a second grid user.
  - The SGR Power Plant will be sharing the physical connection of the industrial grid user for which it used to be a Local Production;
  - The access holder signing Annex 3 of the Access Contract must designate a responsible BRP.

#### **7.3.2.2 Subject of the SGR Contract**

By concluding a SGR Contract, the SGR Supplier will undertake to:

- provide the SGR Service during the five months of the Winter Period;
- keep their SGR Power Plant(s) out of the market throughout the validity period of the SGR Contract (art. 7sexies §5 of the Electricity Law).

The SGR Contract will determine on a non-discriminatory and transparent way additional requirements and terms of reference, including penalties for not complying with availability and activation requirements.

#### **7.3.2.3 Relationship between the SDR Contract and other contracts**

SDR Candidates selected on the basis of the Admission procedure and certification criteria must be aware of the mutual relationships that will exist between the SDR Contract, the BRP Contract and the Access Contract.

#### **7.3.2.4 Subject of the SDR Contract & Functioning Rules**

By concluding a SDR Contract, the SDR Supplier will undertake to provide the SDR Service during the five-month Winter Period(s) of the SDR Contract's validity period.

The SDR Contract will determine on a non-discriminatory and transparent way additional requirements and terms of reference, including penalties for not complying with availability and activation requirements.

#### **Structure of offers (bidding sheets & bidding instructions)**

SGR and SDR Candidates will have to make their offers in a bidding sheet, the rules for which are laid down in the bidding instructions.

### **7.3.3**

#### **7.3.3.1 Bidding principles for SGR Candidates**

The duration of this contract is one year, starting from 1 November of each year for which, on the instructions of the Minister, a volume of strategic reserve from SGR is provided.

As stipulated in the law, in accordance with article *7quinquies*, §3bis of the Electricity Law, SGR Candidates are obliged to submit at least one offer for the production unit(s) concerned. These offered volumes must be divisible. In the first place, SGR Candidates must be able to offer every possible configuration of the (candidate) SGR Power Plant(s) which was technically possible at the moment of announcement to close.

If the Candidate SGR Power Plant is (was) included in a CIPU Contract, the parameters submitted in connection with SGR may differ from those declared in connection with the CIPU Contract, which may also be updated accordingly if necessary. In any case, all data must be justifiable and provable.

The bidding sheets will provide a reference for the fuel prices (e.g. gas, fuel oil, CO<sub>2</sub>, or other) for calculating the total cost. This parameter is determined based on the specific consumption of the type of SGR Power Plant concerned and the published price expected on the market of the fuel used by this SGR Power Plant (SFprice) according to the method described in the CIPU Contract.

SGR Candidates will have the chance to explain in detail the conditions or constraints for their offer to be valid. The bidding instructions will specify how the SGR Candidate will have to prove these conditions or constraints.

These principles and others will be detailed in the bidding instructions.

#### **7.3.3.2 Bidding principles for SDR Candidates:**

To ensure a level playing field for all candidates, candidates need to respect the Bidding Instructions<sup>22</sup> and should be aware of how offers are treated by ELIA.

The duration of this contract is one year, starting from 1 November of each year for which, on instruction of the Minister, a volume strategic reserve from SDR is provided.

For each (combination of) Delivery Point(s), based on the decrease of the SDR portfolio (Rref<sub>DR</sub>) as well as the possible activation of Emergency Generators in SDR (Rref<sub>EG</sub>), having received a maximum SDR Reference Power as a result

---

<sup>22</sup> Available at: <https://www.elia.be/en/electricity-market-and-system/document-library>

of the Certification, the SDR Candidate can submit one or more offer(s), for which:

- The  $UM_{SDR}$  or  $SL_{SDR}$  value is greater or equal to that for which the Delivery Point is certified;
- $Rref_{SDR} \leq Rref_{DR} + Rref_{EG}$
- The  $SL_{SDR}$  and  $UM_{SDR}$  meet the following requirement:
  - $SL_{SDR} \geq SL_{DR} - Rref_{EG}$
  - $UM_{SDR} \geq UM_{DR} - Rref_{EG}$

Offers that do not comply with the Certification will be rejected.

The following obligations should be at minimum respected when offering

1. Smallest Offered Volume

SDR Candidates may submit several offers covering the whole of the contractual period, whether or not the volume is divisible, with a minimum volume of 1 MW and a maximum of 10 MW for the smallest offered volume. Exceptions can be made for units whose production process limits the units technically to supply less than 10 MW. The necessary substantiation will be required. An Example can be found in the Bidding Instructions<sup>22</sup> for SDR.

2. Volume Increments

When sorting the offers in terms of offered volume, the difference between 2 Capacity Bids can be at maximum, 10 MW. Capacity Bids for a smaller volume are allowed and strongly encouraged.

However, exceptions can be made for units whose production process limits the units technically to supply less than 10 MW. The necessary substantiation will be required. An Example can be found in the Bidding Instructions<sup>22</sup> for SDR.

3. Total Cost

The total cost (unit price  $\times$  volume) of the smallest volume that can be retained resulting from a Capacity Bid, should never exceed the total cost of the smallest volume that can be retained from a Capacity Bid with a larger offered volume. In other words, the total cost for a volume should not exceed the total cost of a larger volume.

These principles and others will be detailed in the bidding instructions.

### 7.3.3.3 Bidding sheets

The bidding instructions will at least detail how to submit the following elements in the bidding sheets:

- An offer number serving as a reference [Offer no.]
- Product [ SGR  
/SDR4\_DROP\_BY/SDR4\_DROP\_TO/SDR12\_DROP\_BY/SDR12\_DROP\_TO]
- Certified combination number (only for SDR)
- Offered volume [MW] – minimum bid size = 1MW
- Reservation Price [€/MW/h]

- Fixed activation cost (cold) [€/Notification]
- For SGR only per offer line:
  - contractual period
  - Configuration type
  - activation energy (cold) [GJ/Act]
  - fixed activation cost (hot) [€/Notification]
  - activation energy (hot) [GJ/Act]
  - average and variation range of external costs (excluding CO<sub>2</sub> cost) [€/MWh]
  - start fuel type [Fuel type]
  - operational fuel type [Fuel type]
  - prolongation fuel [Fuel type]
  - various components that determine the variable activation price [€/MWh]
- For SDR only:
  - variable activation price [€/MWh]
  - prolongation cost [€/hour]
- Shedding Limit,  $SL_{DR}$ , SDR DROP-TO or Unsheddable Margin,  $UM_{DR}$ , SDR DROP-BY for each Delivery Point may not be combined with [Other Offer no.]
- Divisible [Y/N].

#### 7.3.4

##### **Contractual Data form**

The contractual data form contains all information to be provided in the Annexes of the SDR/SGR Contract specific to each SGR and SDR Supplier.

## Final Offer

### Conditions for the submission of the offers

In order to be valid, an offer must be sent by registered mail or carrier to following address:

- 7.4** ELIA Transmission Belgium - Arno Motté  
20 Boulevard de l'Empereur  
**7.4.1** B - 1000 Brussels

Each offer must consist of an original paper version and an electronic copy and must be sent to [arno.motté@elia.be](mailto:arno.motté@elia.be) and [contracting\\_SR@ELIA.be](mailto:contracting_SR@ELIA.be).

If there is a discrepancy between the electronic version and the printed version, the original paper copy shall prevail.

The offers must be complete and received by ELIA before 6 p.m. CET at the latest on 14 May 2021.

The SGR/SDR Candidate shall state clearly which information is confidential and/or related to technical and commercial secrets.

The offers have to be written in either French, Dutch or English.

### Data & additional documents to be added to the offer

- 7.4.2** The SGR and SDR Candidates are obliged to use the bidding sheet provided by ELIA. In addition to the completed bidding sheet as specified in the bidding instructions, the offers must include the following information in order to be considered valid:

For both SGR as well as SDR Candidates:

- The authority of the person signing the offer.
- Contractual data as specified in the Call for Tender documents.
- The date on which said person signed the tender.
- The signature of the person authorised to sign the tender.

For SGR Candidates only:

- 7.4.3** • Proof of any constraints as specified in the bidding instructions.

### Validity of the offers

SGR and SDR Candidates are bound by their offer until 31 October 2021.

The prices and volumes of submitted offers are firm and binding throughout the period of validity of the offers. Deviation is only possible to the extent that the Minister exercises his authority under article 7sexies, §4 of the Electricity Law by imposing the necessary prices and volumes with regard to a specific offer.

SDR and SGR Candidates must be aware that submitting a final offer means that if the SDR/SGR Candidate is awarded an SGR/SDR Contract, but the SDR/SGR Service cannot be started on 1/11/2021, because of non-fulfilment of one of the conditions mentioned in 7.6, the SDR/SGR Candidate will be liable for the damages as a consequence of the non-fulfilment of these conditions. As a result, ELIA can recover the unavailability of that part of the strategic reserve and all costs and other damages related to it up to a maximum amount as specified in the General Terms and Conditions of strategic reserve. Besides that, depending on the conditions not being met, penalties will be applicable as defined in the SDR or SGR Contract.

In the negotiated procedure, all elements of the Specifications are considered as essential and must be respected by tenderers, otherwise their tenders shall be considered null and void.

## Awarding

The criteria for the most optimal techno-economical combination of offers are set out in the CREG approved Functioning Rules under 5.4. Since the approved Functioning Rules have to be published prior to the Call for Tender, this will be transparent for all SGR and SDR Candidates.

**7.5** There are two possible scenarios after 1 September 2021:

1. There are sufficient non-manifestly unreasonable offers to cover the volume requested in the instructions of the Minister;
2. There are insufficient non-manifestly unreasonable offers to cover the volume requested in the instructions of the Minister.

In case of sufficiently non-manifestly unreasonable offers (scenario 1), ELIA will make a techno-economical selection of all these offers and award them no later than 13 September 2021:

- The awarding of the offers is done in a way that ensures that the contracted volume of strategic reserve (SDR and SGR) is at least the volume determined by the Minister and this at the lowest possible total cost, in accordance with the criteria set in the Functioning Rules approved by the CREG.
- ELIA will inform the SGR and SDR Candidates about the award of an SDR or SGR Contract by e-mail and by registered mail, after taking the decision based on the above-mentioned award criteria by 13 September at the latest.

Even in the case of insufficiently non-manifestly unreasonable offers (scenario 2), the share of non-manifestly unreasonable offers will be awarded by ELIA as under scenario 1.

For the manifestly unreasonable offers, the Minister will set up prices and volumes in application of article 7<sup>sexies</sup>, §4 of the Electricity Law. An imposition of prices and volumes by Ministerial Decree falls outside the scope of this Procedure. In such a case, the modalities defined in this Procedure for Constitution of the strategic reserve and the applicable SDR and/or SGR Contracts will automatically become legally applicable to the prices and volumes imposed by the Minister.



## Contracting

### Contract conclusion process

The SGR and/or SDR Candidates that are officially awarded a contract will have to follow the contract conclusion process to sign the contract as soon as possible before the start of the service delivery.

- 7.6** Note: The fact that an SDR or SGR Contract with ELIA has been concluded does not prevent the CREG from adapting the Functioning Rules that ELIA has had to submit to CREG.

### Conditions for starting the SDR or SGR Service

Before the start of the Contract there are some conditions that must be met:

- 7.6.2**
- All SGR and/or SDR Suppliers must pass a Simulation Test as described in the SGR/SDR Contract. ELIA reserves the right to request additional Simulation Tests before the beginning of the contract in case previous Simulation Tests have failed.
  - As stipulated in art. 7.1.2, SDR Delivery Points must fully comply with the conditions for the Transfer of Energy Rules before being able to plan a Simulation Test.
  - Delivery Points that are Access Points connected to the Distribution Grid or DSO Submetering Delivery Points must be covered by a DSO-SDR Supplier contract<sup>23</sup>.
  - TSO Submetering Delivery Points that will use a Data Logger or a GSM modem must successfully pass a communication test with the ELIA metering data management system (performed by ELIA). This process is called "Commissioning".
  - TSO Submetering Delivery Points must provide a valid proof of Submeter compliance prior to "Commissioning".
  - Delivery Points with TSO or DSO Submetering via a new Submeter (installed after 02 April 2021) must have the new meter installed and a valid proof of Submeter compliance;
  - Delivery points within a CDS must be able to provide valid proof of Submeter Conformity in addition to a signed cooperation agreement between ELIA and the CDS Operator.
- 7.7**

### Contract award notice

Once the Contracts have been signed, ELIA will publish a contract award notice with the results of the tender procedure on the website <http://ted.europa.eu/>. Depending on the result of the tendering procedure, the protection of commercially sensitive information may need an aggregation of it (average price, price range,...).

After the awarding by ELIA and the signing of the contracts, including the publication of the contract award notice, the tendering process organised by ELIA is terminated, without prejudice to the powers granted by art. 7 sexies of the Electricity Act to the Minister.

---

<sup>23</sup> For more information, please consult the document on the Synergrid website: in Dutch : [http://www.synergrid.be/download.cfm?fileId=ContractDSO-FSP\\_R3\\_20161121\\_NL\\_FINAL.docx](http://www.synergrid.be/download.cfm?fileId=ContractDSO-FSP_R3_20161121_NL_FINAL.docx)  
In French : [http://www.synergrid.be/download.cfm?fileId=ContractDSO-FSP\\_R3\\_20161121\\_FR\\_FINAL.docx](http://www.synergrid.be/download.cfm?fileId=ContractDSO-FSP_R3_20161121_FR_FINAL.docx)

It is possible that ELIA contracts a strategic reserve with a power volume in MW that exceeds the level set by the Minister. Such a higher volume can be justified by the foreseeable availability of MW offered as well as by the indivisibility of the offers.

## **Return to the market**

### **General principles of return to the electricity market**

The announcement of the shutdown of an SGR Production Plant can be temporary or definitive.

**8**

**8.1** In accordance with art. 4bis, §1bis of the Electricity Law, a definitive withdrawal period always results in a deactivation or participation in the strategic reserve (except for the hypothesis in which a new production license is applied for and obtained, as stipulated in art. 4 of the Electricity Law).

For temporary decommissioned units, the legal framework provides for the possibility of revoking the announcement of the temporary deferment. This framework clarifies from which moment the return to the market is possible and this accordingly to the time when the renunciation was communicated, the appropriate terms that take into account the procedure and the lead time of the tender of the strategic reserve.

### **Reimbursement of costs that have been remunerated in the context of an SGR Contract**

**8.2**

Production units that are willing to provide an SGR service can include the investment costs or costs for major maintenance work, in order to make the production unit conform to the technical requirements, in the remuneration by ELIA. However, if the production unit returns to the market, part of this compensation must be repaid. Therefore, detailed information on SGR costs should be submitted directly to CREG (not ELIA) in the format set by CREG. The following conditions must be lived up to:

- The total of these costs must correspond with the offer submitted by the SGR Candidate.
- The necessity of this investment and maintenance work needs to be proven.
- After carrying out major maintenance activities, a specification of the number of years and operating hours of the lifetime of the investment or the lifetime extension of the production unit is required.

**9**

If the Production Unit is sold or if the control is transferred to a third party, all obligations arising from the SGR Contract must be paid by the acquirer; in such cases, ELIA reserves the right to demand the necessary sureties from the acquirer, including bank guarantees to the amount of the uncollected part. In the event of refusal or the absence of the creation of the security, the amount to be repaid will become immediately due and payable.

## **Rules regarding disputes**

Without prejudice to other remedies, where an SGR or SDR Candidate believes they have been adversely affected by an error or irregularity allegedly committed in relation to this procurement procedure, or that the procedure was tainted by any maladministration, they may file a complaint with ELIA.

Any remaining dispute regarding the interpretation or implementation of this procedure or subsequent agreements or operations that might arise therefrom shall be submitted to the courts of Brussels.

## Cancelling the tendering procedure

ELIA reserves the right to cancel the tendering procedure before the SDR/SGR Contract(s) is (are) signed, without the SGR and SDR Candidates being entitled to claim any compensation.

- 10** Cancellation may occur if the legal basis, including the implementing regulation, becomes ineffective, due to its annulment, suspension or withdrawal or is modified in its essential characteristics, leading to the non-conformity of the tender with said legal basis.

If the procurement/tendering procedure is cancelled, all SGR and SDR Candidates will be notified in writing as soon as possible of the reasons for the cancellation.

## Modification of the instruction of the Minister

- 11** In case of modification of the Ministerial Decree instructing ELIA to launch the constitution of the strategic reserve and without prejudice to a possible decision to adjust the volume of the strategic reserve, ELIA reserves the right to further define the tender until the date of the Call for Tender, to take due account of such modification.

In the event that the Minister, in accordance with art. 7 quarter of the Electricity Law, no later than 1 September of each year, on the basis of an updated analysis of the system operator and advice from the General Direction Energy, by means of a Ministerial Decree deliberated in the Council of Ministers would review the required volume of the strategic reserve to 0 MW, the tendering procedure will be stopped and in such a case the awarding will not proceed.

## 12

### Questions

Questions relating to this Procedure for Constitution of Strategic Reserve should be addressed to: Arno Motté ([arno.motté@elia.be](mailto:arno.motté@elia.be)), Contracting\_SR ([contracting\\_SR@elia.be](mailto:contracting_SR@elia.be)).