

## Determination of balancing capacity 2019

- LFC Block Operational Agreement
- Dossier Volume 2019

**Working Group Balancing**  
**September 14, 2018**

# Agenda

## **1. LFC block Operational Agreement**

1. Legal Framework : SOGL, EBGL and FGC
2. LFC block Operational Agreement
3. Results of the public consultation on LFC block Operational Agreement

## **2. Dossier Volume 2019**

1. Status Dossier Volume
2. Static upward FRR needs and means
3. Dynamic downward FRR needs and means

# LFC block Operational Agreement

# Legal Framework: SOGL, EBGL and FGC

- **Federal Grid Code (Art 233) :**
  - “Le gestionnaire évalue et détermine la puissance de réserve primaire, secondaire et tertiaire [...]. Il communique pour approbation à la commission sa méthode d'évaluation et le résultat de celle-ci.”
    - The Dossier Volume 2019 facilitates the procurement of R1, R2 and R3
    - A new Federal Grid Code is foreseen to enter into force during 2019
- **System Operation Guidelines (Art 119) :**
  - The TSO develops a LFC block operational agreement containing the dimensioning principles of FRR, as well as operational procedures to ensure balancing quality in the LFC block.
    - Subject to public consultation and regulatory decision (latest 6 months after submission)
    - Entry into force foreseen in 2019 requires Dossier Volume to be compliant with these principles
- **Electricity Balancing Guidelines (Art 32)**
  - The TSO shall at least once a year review and define the reserve capacity requirements, i.e. FRR means, for the LFC block or scheduling areas of the LFC block pursuant to dimensioning rules.
    - Integrated in Dossier Volume 2019 as a transitory measure
    - Relevant articles applicable from December 2018 requires Dossier Volume to be compliant with these principles

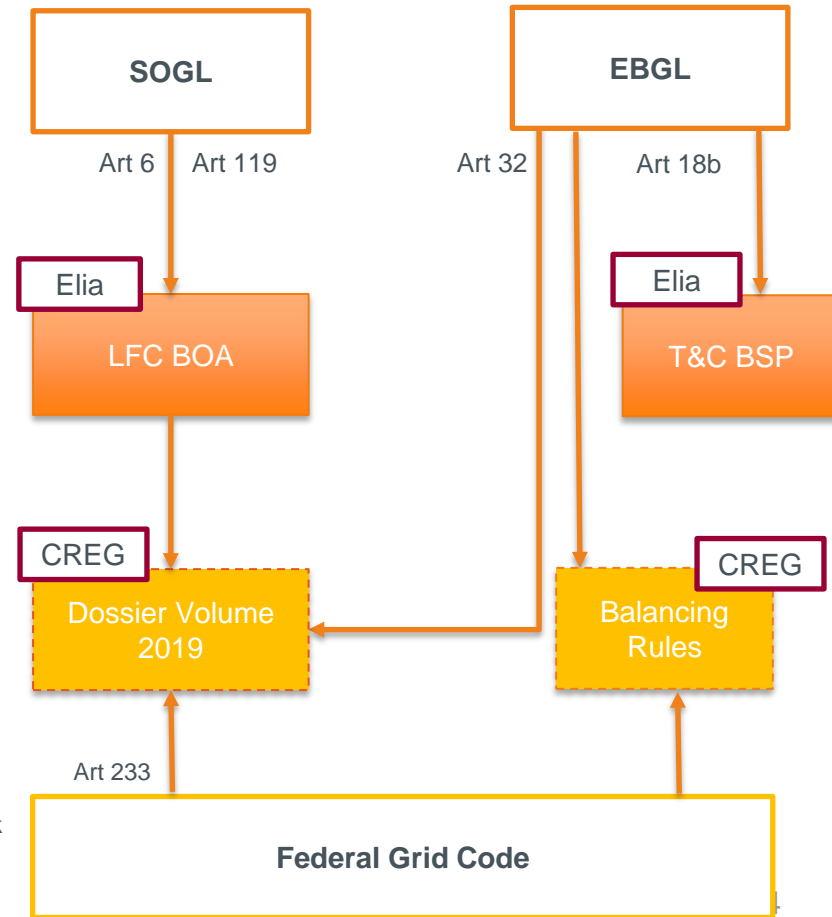

# LFC Block operational agreement

## SOGL – Art. 3 “Definitions”

“LFC block operational agreement’ means a multi-party agreement between all TSOs of a LFC block if the LFC block is operated by more than one TSO and means a LFC block operational methodology to be adopted unilaterally by the relevant TSO if the LFC block is operated by only one TSO”

### 1. It is complementary to a Synchronous Area Operational Agreement (Art. 118)

1. Drafted by all TSOs by 12 months after entry into force of the SO GL (= 14/9/2017) and to be approved by all NRAs
2. Determines the dimensioning and properties of FCR, the sharing of FCR, frequency quality monitoring and operational procedures to restore frequency deviations,...
3. Determines roles and responsibilities concerning imbalance netting, cross-border FRR and RR, sharing and exchange of FRR and RR,...

### 2. The SOGL specifies the content of the LFC Block Operational Agreement (Art. 119)

1. Drafted by all TSOs by 12 months after entry into force of the SO GL (= 14/9/2017) and to be approved by all NRAs
2. Determines the dimensioning rules of FRR and RR
3. Determines the common procedures to fulfill the obligations of load-frequency control

- While the SAOA deals with the cooperation of TSOs within (and between) synchronous areas, the LFCBOA deals with **the cooperation of TSOs within (and between) LFC blocks. While some LFC Blocks consist in different LFC areas (e.g. Germany), Elia is the sole TSO in its LFC Block.**

**A part of the SOGL requirements is not applicable for Elia’s LFC block**

# Content : LFC BOA

## Elements subject to Art. 6

LFCBOA Article	Art. 119 Requirement	Summary
<b>Art. 3</b>	Ramping restrictions for active power output in accordance with Article 137(3) and (4);	<p>*Ramping restrictions NEMO aligned with NGET (and other neighbors).</p> <p>*No ramping restrictions on demand units and generators</p>
<b>Art. 6 - 9</b>	the FRR dimensioning rules in accordance with Article 157(1);	<ol style="list-style-type: none"> <li>1. Dimensioning rules for positive capacity on FRR</li> <li>2. Dimensioning rules for negative capacity on FRR</li> <li>3. Determination ratio aFRR/mFRR</li> <li>4. Determination of maximal sharing capacity</li> </ol> <p>NB. Allocation of the means is not covered as this is still covered in Dossier Volume 2019.</p>
<b>Art. 4</b>	measures to reduce FRCE by requiring changes in the active power production or consumption of power generating modules and demand units in accordance with Article 152(16);	<p>*Supplementary to normal activation procedures and emergency procedures</p> <p>*Facilitates use of slow-start units (FAT &gt; 15 minutes) when facing risk for high or enduring FRCE (= existing measure)</p> <p>*Stresses exceptional nature and requires ex post justification to CREG</p>
<b>Art. 5</b>	coordination actions aiming to reduce FRCE as defined in Article 152(14);	*Specify that not applicable (one LFC area)

# Content : LFC BOA

## Elements not subject to Art. 6

	Art. 119 Requirement	Summary
<b>Art. 10</b>	LFC block monitor in accordance with Article 134(1);	<ul style="list-style-type: none"> <li>*Specify Elia as LFC block monitor</li> <li>*Trimestral reporting following SOGL, SAOA (CREG)</li> </ul>
<b>Art. 11</b>	operational procedures in case of exhausted FRR or RR in accordance with Article 152(8);	<ul style="list-style-type: none"> <li>*Refers to the FRCE measure (activation slow-start units) upon depletion (or risk to) depletion of FRR means (=existing mechanism)</li> <li>*Specify exceptional nature and requires ex post justification to CREG (report)</li> </ul>
<b>Art. 12</b>	the escalation procedure defined in accordance with Article 157(4) and, if applicable, the escalation procedure defined in accordance with Article 160(7)	<ul style="list-style-type: none"> <li>*Procedures in case of unavailability of contracted balancing capacity</li> <li>*Use of existing re-dispatch procedures (e.g. in case of congestion)</li> <li>*Specify exceptional nature and requires ex post justification to CREG (report)</li> </ul>
<b>Art. 13</b>	the FRR availability requirements, the requirements on the control quality defined in accordance with Article 158(2), and if applicable, the RR availability requirements and the requirements on the control quality defined in accordance with Article 161(2);	<ul style="list-style-type: none"> <li>*Specify full activation time (7,5 min for aFRR and 15 min for mFRR)</li> <li>*Specify full availability (100% availability)</li> <li>*Specify demonstration compliance with control criteria by means of qualification process</li> <li>➔ Refers to Terms and Conditions BSP</li> </ul>
<b>Art. 14</b>	the roles and the responsibilities of the control capability providing TSO, the control capability receiving TSO and of the affected TSO for the sharing of FRR and RR defined in accordance with Article 166(7);	*Refers to definitions of the SOGL control providing TSO, and control receiving TSO
	the roles and the responsibilities of the control capability providing TSO, the control capability receiving TSO and of the affected TSO for the sharing of FRR and RR between synchronous areas in accordance with Article 175(2);	

# Other non-relevant elements of Art 119

## Art 119 (additional relevant paragraphs)

<b>A</b>	where the LFC block consists of more than one LFC area, FRCE target parameters for each LFC area defined in accordance with Article 128(4);
<b>D</b>	where the LFC block is operated by more than one TSO, the specific allocation of responsibilities between TSOs within the LFC block in accordance with Article 141(9);
<b>E</b>	if applicable, appointment of the TSO responsible for the tasks in Article 145(6);
<b>F</b>	additional requirements for the availability, reliability and redundancy of technical infrastructure defined in accordance with Article 151(3);
<b>I</b>	the RR dimensioning rules defined in accordance with Article 160(2);
<b>J</b>	where the LFC block is operated by more than one TSO, the specific allocation of responsibilities defined in accordance with Article 157(3), and, if applicable, the specific allocation of responsibilities defined in accordance Article 160(6);
<b>M</b>	if applicable, any limits on the exchange of FCR between the LFC areas of the different LFC blocks within the CE synchronous area and the exchange of FRR or RR between the LFC areas of an LFC block of a synchronous area consisting of more than one LFC block defined in accordance with Article 163(2), Article 167 and Article 169(2);
<b>N</b>	the roles and the responsibilities of the reserve connecting TSO, the reserve receiving TSO and of the affected TSO for the exchange of FRR and/or RR with TSOs of other LFC blocks defined in accordance with Article 165(6);

- *Elia assesses that these elements are not relevant for ELIA LFC Block.*
  - *Following consisting of 1 LFC Area, or Elia being the sole TSO*
  - *Following no RR, or FRR exchange in 2019 for ELIA LFC Block*



# Public Consultation

**Two answers are received which are non-confidential. A consultation report will be published on Elia's website after submission to CREG (September 14, 2018)**

## Febeliec (summary)

FEBELIEC agrees with the dimensioning of the positive and negative FRR reserve capacity as it is line with discussions in Working Group as FEBELIEC position on this point

FEBELIEC hopes to be informed of all evolutions of this document as well as the related operational documents and calculations and has specific questions on :

- **Impact of the 30% N-1 cap for sharing**
- **Transparency on NEMO forecast tool**
- **Information on the exhausted reserve procedure**

## Febeg (summary)

- FEBEG remarks that this document sets the regulatory basis for several methodologies and procedures which have not been presented or discussed in the task force, for example :
  - **Impact of congestion management**
  - **Impact of offshore wind**
  - **Dimensioning of the volumes of different products**
- FEBEG preserves the right to question this proposal if it – in a later stage - blocks the implementation of methodologies of procedures.

# Elia's answers on the public consultation (1)

On discussing relevant methods and procedures in the working group...

- **LFCBOA specifies the general principles of existing methodologies and procedures**
  - On static and dynamic sizing of up- and downward FRR needs (as discussed in WG)
  - On use of slow-start units (flexibility > 15 minutes) as currently in the balancing rules. Elia further specifies and constrains the use by means of exhausted reserve procedure (following depletion of reserves), and FRCE measure (following high ACE-values) foreseen by SOGL
    - defining it as exceptional measures (not expected to be used in practice)
    - specifying obligations on reporting when using these procedures
  - On use of re-dispatch measures as currently under CIPU-procedures. Elia further specifies and constrains the use by means of escalation procedure (following unavailability of reserves) similar as the exhausted reserve procedure.
- **The implementation of new or modifications of existing methods or procedures will be discussed with the stakeholders:**
  - Via an update of the LFCBOA (subject public consultation)
  - In framework of Dossier Volume 2019 (subject to public consultation)
  - Or other official documents where appropriate

# Elia's answers on the public consultation (2)

## On FEBELIEC's questions regarding the dimensioning methodology

- **On the impact of the sharing cap of 30% of the dimensioning incident**
  - This is a legal obligation of the SOGL (if impact it would be outside's Elia's control)
  - The implementation of these rules is detailed in the Dossier Volume 2019
- **On transparency of the probabilistic approach for NEMO-link prediction model**
  - Elia always committed to be as transparent as possible on input-output data once the daily dimensioning has direct impact on balancing capacity to be procured
  - If Dossier Volume 2019 would show that there is no need to contract downward FRR, Elia will not publish on regular basis but publish an analysis after observing a full year of results in 2019
- **On the exhausted reserve procedure**
  - Elia' refers to the existing framework foreseen in the Balancing Rules
  - This will be facilitated under exhausted reserve procedure subject to justification (cfr. earlier)
  - Modifications will be presented and discussed with stakeholders

# Elia's answers on the public consultation (3)

## On FEBEG's questions regarding the dimensioning methodology

- **On impact of congestion management on the dimensioning**
  - Escalation procedure is foreseen for specific reasons of unavailability of balancing capacity providing units
  - Re-dispatch procedures under CIPU can be used when unavailability of FRR means (e.g. congestion)
  - Specifies the obligations concerning reporting when using the mechanism (cfr. earlier)
  - Dimensioning method does not foresee to take into account the need for reserve capacity for congestion reasons. This would not be compliant with SOGL
- **On impact of offshore wind on the dimensioning**
  - Storm Risk study specifies that storms can be predicted by BRP at least a few hours in advance
  - Elia believes that BRPs will be capable in managing the situation (not defendable to contract reserves)
  - Elia presents in the Working Group of September 10<sup>th</sup> a specific operational measure if BRPs fail to cover the risk
- **On impact of dimensioning of the volumes of different products**
  - Scope of LFCBOA limited to FRR needs and ratio aFRR versus mFRR (Article 119 SOGL)
  - Allocation to FRR means out of scope (Article 32 EBGL)
    - Currently in Dossier Volume 2019
    - Allocation **R3flex and R3standard** is elaborated in Dossier Volume 2019

# LFC block operational agreement

## Next steps

- Elia did not need modify content of the LFCBOA or the Explanatory Note following the remarks received
- **LFC BOA is a regulated document** with main principles (including FRR needs dimensioning) compliant with SOGL :
  - Elia will submit LFCBOA (including element other as Article 6) the latest on September 14, 2018 to CREG
    - LFCBOA in three languages
    - Explanatory Note
    - Consultation report
- According to the SOGL, CREG can decide on the document within 6 months (before March 14, 2019),
  - LFCBOA can enter into for 3 months after approval by CREG (Article 15) (= June 14)
  - SOGL foresees possible mechanisms for revision when amendments are required, which may impact this timing
- Dossier Volume 2019 is written conform with LFCBOA (concerning the dimensioning of the FRR needs)

# Dossier Volume 2019

---

# Dossier Volumes

The 'Dossier Volumes' deals with the dimensioning of FCR, aFRR and mFRR

- Application of the Federal Grid Code Art 233
  - + Conform the LFC block Operational Agreement (after its approval and entry into force)
  - + Conform the System Operation and Electricity Balancing GuideLines (SOGL & EBGL)
- The TSO will send the **methodology** and **results** to the CREG for approval
- The CREG will consult stakeholders

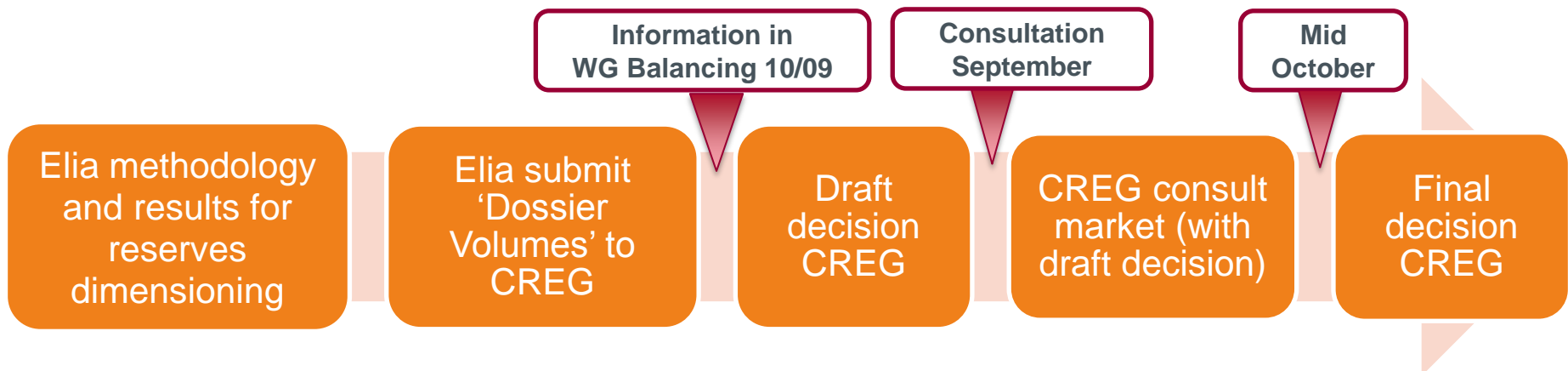

# Dimensioning FCR (R1)

Frequency Containment Reserves (R1) is **joint responsibility** of all TSOs of RG Continental Europe (determined by ENTSO-E)

- Joint action to stabilize frequency after occurrence of an imbalance in the Synchronous Area
- Methodology will be specified in the Synchronous Area Operational Agreement (SAOA)

**For 2019: Total volume of 3000 MW FCR within RG Continental Europe.**

- Simultaneous outage of two of the largest power plants in RG CE.
- Split amongst TSOs is defined by ratio of the (generation + **consumption**) of the LFC block compared to the (generation + **consumption**) of the Synchronous Area

Split of volumes is only determined end 2018 for next year and will be communicated separately by ELIA as soon as it is known



# Terminology FRR (conform with network guidelines)

## FRR needs: Art 3 & Art 157 SOGL

- *Reserve capacity on FRR, as well as the ratio aFRR and mFRR, to cover LFC block imbalances, determined by means of the dimensioning principles in Article 157.*
  - *'frequency restoration reserves' or 'FRR' means the active power reserves available to restore system frequency to the nominal frequency and, for a synchronous area consisting of more than one LFC area, to restore power balance to the scheduled value;*



## FRR means: Art 2 & Art 32 EBGL

- *Balancing Capacity: a volume of reserve capacity that a balancing service provider has agreed to hold and in respect to which the balancing service provider has agreed to submit bids for a corresponding volume of balancing energy to the TSO for the duration of the contract; (= puissance de reserve secondaire et tertiaire: R2, R3flex, R3std)*
- *Sharing of reserves (definition SOGL): a mechanism in which more than one TSO takes the same reserve capacity, being FCR, FRR or RR, into account to fulfil their respective reserve requirements resulting from their reserve dimensioning processes; (formerly referred to as inter-TSO contracts, transformed into sharing agreements)*
- *Non-contracted balancing energy bids (not specifically defined): expected to be available both within their control area and within the European platforms taking into account the available cross-zonal capacity (= offres d'énergie d'équilibrage non-contractée: free bids or incremental / decremental bids)*

# Upward FRR

---

## Workplan FRR as discussed in WG Balancing

**Elia plans to implement a dynamic dimensioning:**

- **In 2019 for downward FRR needs based on a simplified approach (outage only)**
  - Outage risk: Q1 2019 Nemo will come online impact on N-1 downwards
  - Upward FRR remains static in 2019
- **In 2020 for downward and upward FRR needs based on advanced approach (machine learning)**
  - Parallel runs and testing of advanced methods during 2019
  - Prediction risk: Q4 2019 increase in offshore wind
- **Daily tendering is a prerequisite to calculate in a dynamic way the contracted balancing capacity**

# Dimensioning methodology FRR (R2+R3)

Deterministic methodology

Probabilistic methodology

**FRR needs must always cover dimensioning incident (N-1)**

FRR needs =  
Maximum value of  
both methodologies

## Step 1 – FRR needs

- Calculation of the total expected LFC block imbalances in 2019
- Calculation of **FRR needs** required to cover **99,0%** of these imbalances (R2+R3)
- **FRRneeds = Max(DET N-1; PROB99)**

Compared to 99.9% in 2018 :

- Minimum reliability level defined by SOGL (Art. 157)
- Elia attains ENTSOe balancing quality criteria

## Step 2 – ratio aFRR / mFRR needs

- Calculation of the expected variations of LFC block imbalances in 2019
- Determination of the **aFRR (R2) needs**

## Step 3 – FRR means

- Determination of the **aFRR (R2) balancing capacity**
- Determination of **mFRR (R3) portfolio** required in addition to aFRR volume to cover the total FRR needs

# Step 1 : Determination FRR Needs

## Calculation of expected LFC block imbalances in 2019

- Based on observed system imbalance in 2017-18
  - Corrected for forced outages
  - Improvement factors
- Additional forecasting errors due to RES
  - Forecast errors PV and Wind in 2017
  - Extrapolated to incremental capacity 2019
  - Improvement factors
- Forced outages are simulated
  - Monte Carlo simulation on power plant outages (probability, duration, capacity)
  - Excluding storm risks (compared to 2018)
  - Including NEMO-link (compared to 2018)

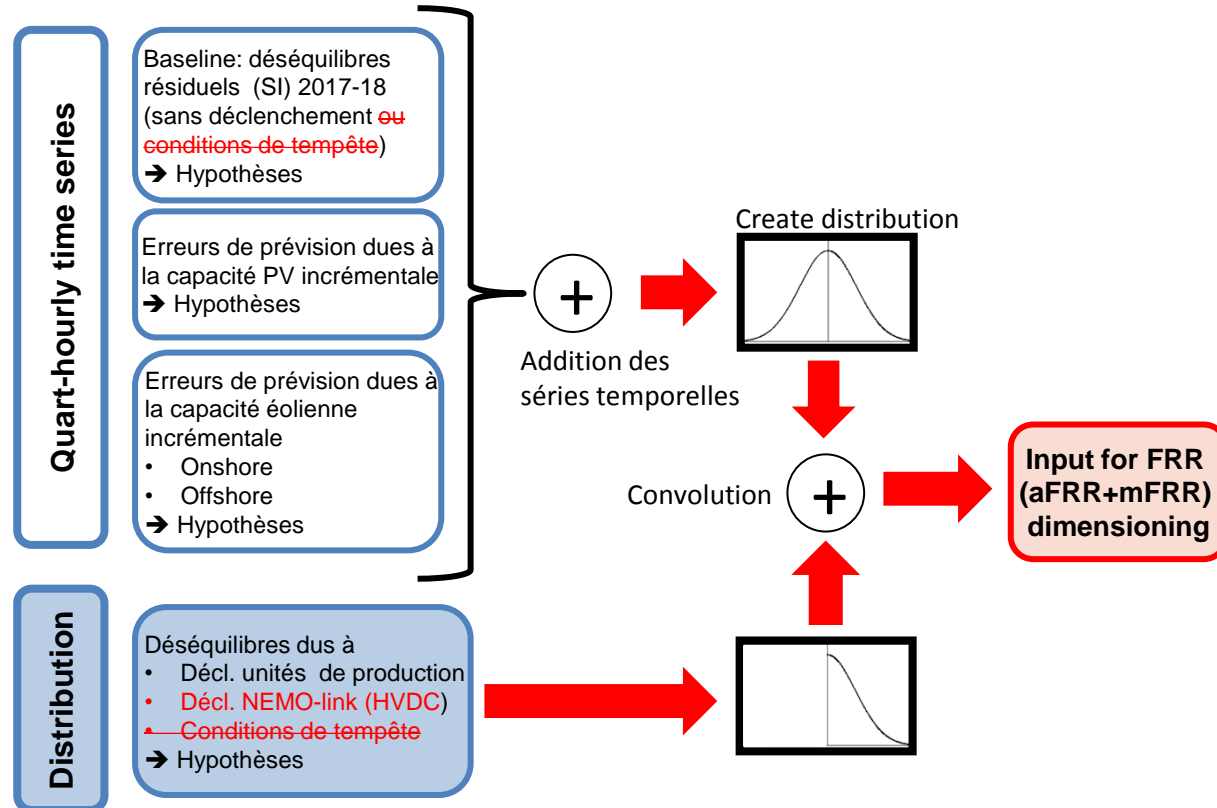

In the previous years, the historic system imbalance was corrected for offshore storm cut-offs, which were modelled separately as a forced outage risk. Following the results of the storm risk study, it is concluded to not treat these as forced outage in the dimensioning.

HVDC-interconnector NEMO-link in simulations accounting for forced outage during import or export (planned entry into operation during Q1 2019)

# Step 2 : Determination aFRR and mFRR needs

## Calculation of the variability of the system imbalance

- aFRR needs: based on Qh-variations of expected system imbalances in 2019
- FRR needs = aFRR needs + mFRR needs

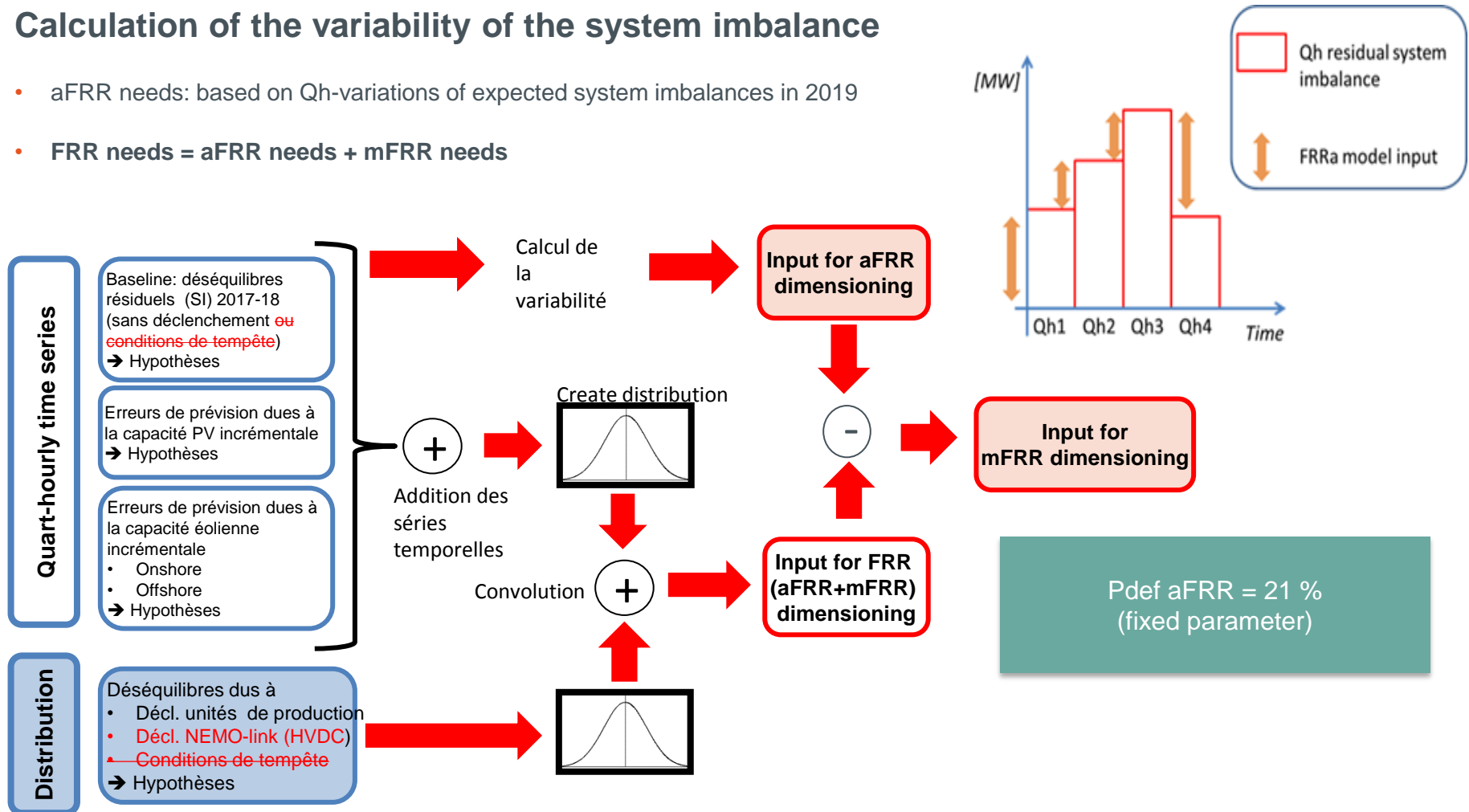

# Results

## FRR needs

Calculation	FRR needs 2019 (99.0%)	FRR needs 2018 (99.9%)
Deterministic Approach	1039 MW (nuclear)	1143 MW (offshore)
Probabilistic Approach	990 MW	1190 MW

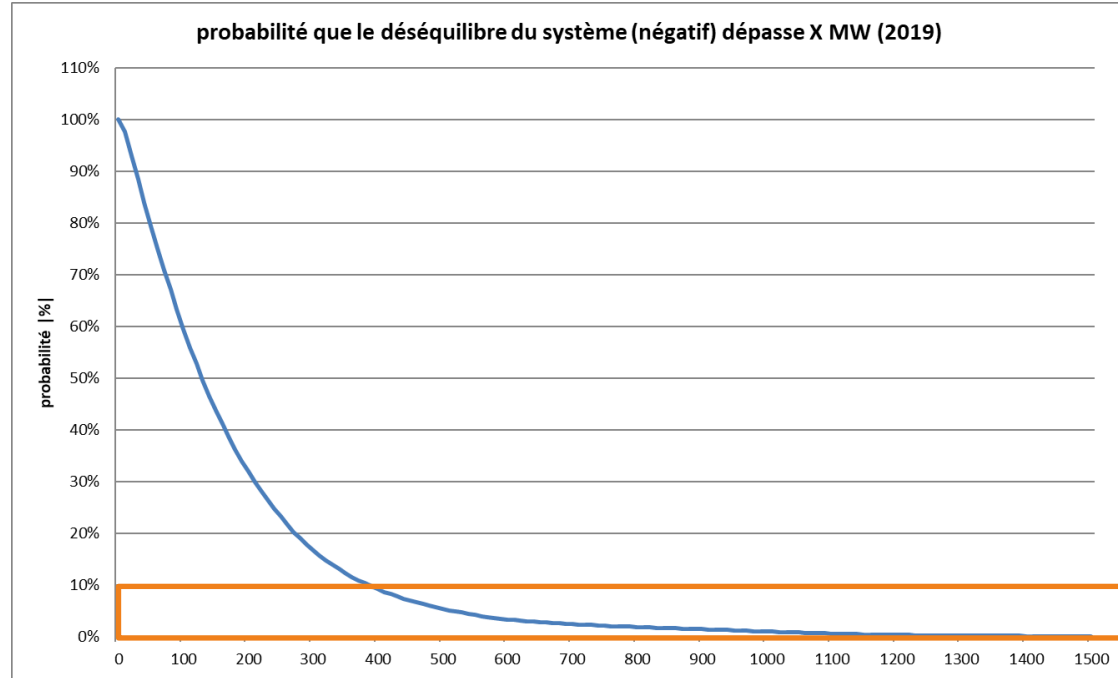

### Observations

- ❑ Balancing criteria quality shows very slight decrease in 2017 while RES capacity increases
  - ❑ Still compliant with ENTSO-e required quality (ACE target parameters)
  - ❑ Elia expects this will improve again in the future (Elia's efforts to better inform the BRPs on system imbalances)
- Pdef is increased from 0,1% to 1,0% reducing the result of the probabilistic analysis to 990 MW
- Dimensioning incident determines the FRR needs to 1039 MW

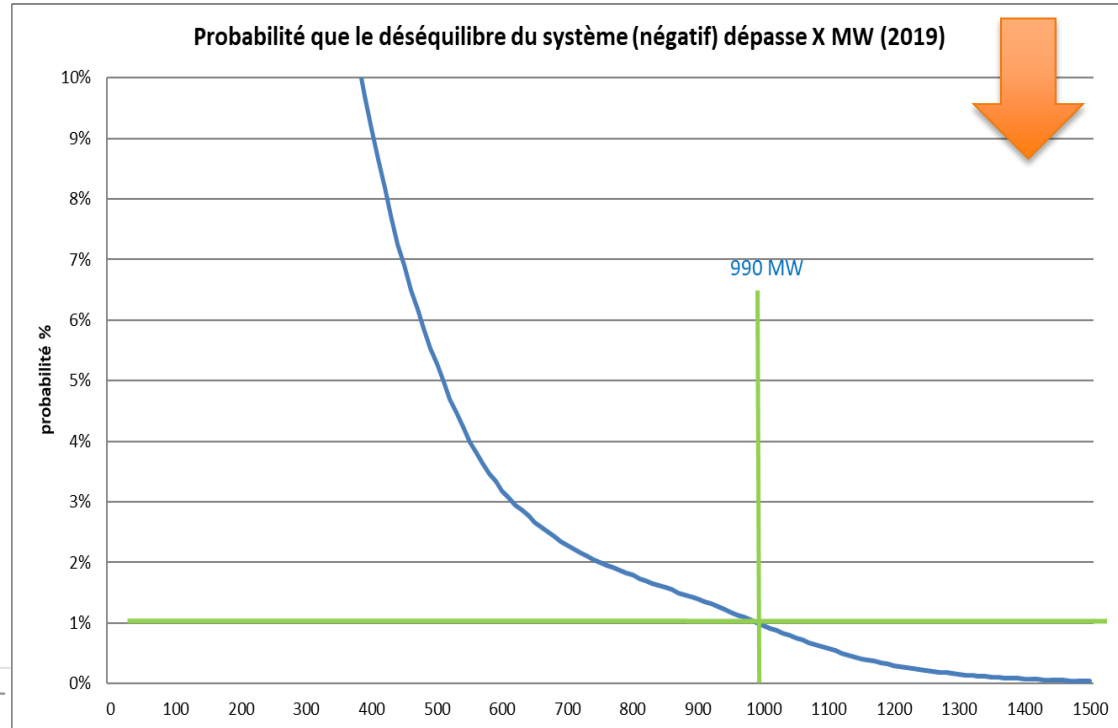

# Results

## aFRR / mFRR needs

aFRR needs	2019 (79%)	2018 (79%)
aFRR needs	145 MW	139 MW

FRR / mFRR needs	FRR needs 2019 (99.0%)	FRR needs 2018 (99.9%)
Total FRR needs	1039 MW	1190 MW
mFRR needs	894 MW	1051 MW

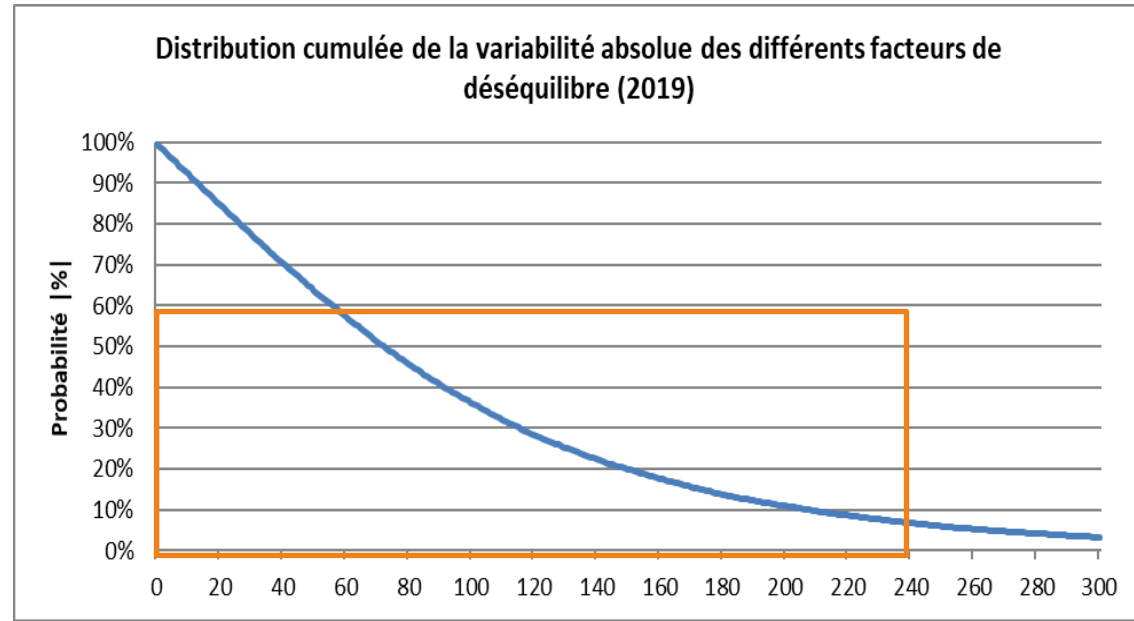

Observations

- SI quality show slight decrease in 2017 while RES capacity increases
- Compliant with ENTSO-e required quality (ACE target parameters)

→ Pdef of 21% is maintained

→ aFRR needs is determined at 145 MW,

→ mFRR needs are determined at 894 MW

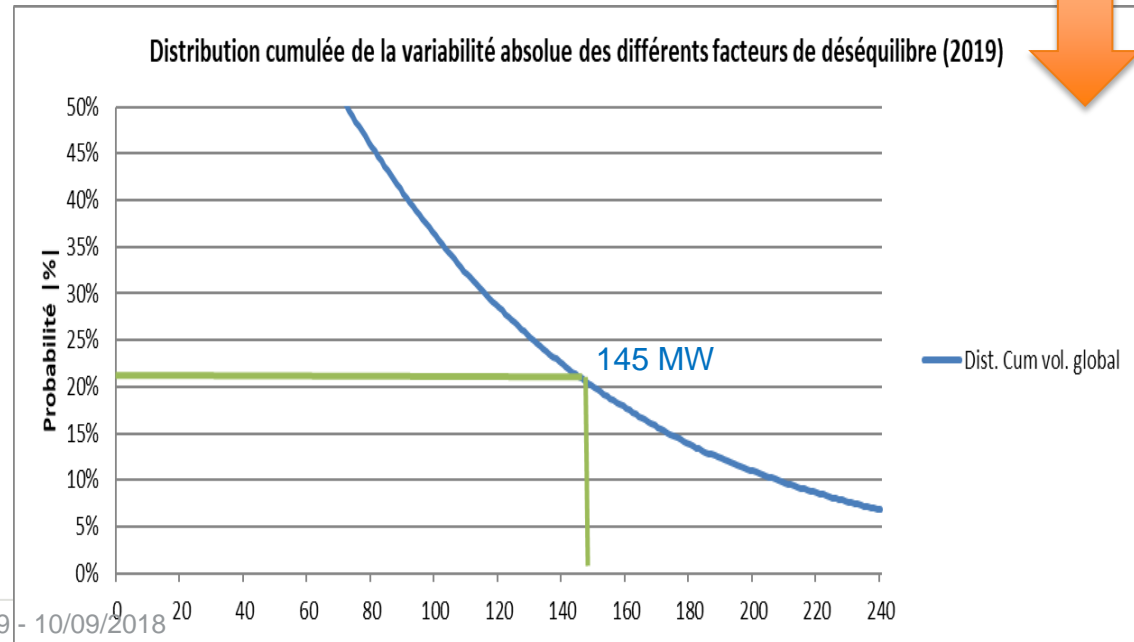



## Step 3: Determination FRR means

- **aFRR is proposed to be covered with contracted balancing capacity**
  - 145 MW
  
- **mFRR needs is proposed to be covered with :**
  - Reserve sharing limited at 50 MW (reduced from 250 MW following Pdef increase)
  - 844 MW balancing capacity (contracted R3flex and R3standard)
    - With a minimum of 314 MW R3standard (phase out R3flex)

Criteria	2019			2018		
DET N-1	1039 (NUKE)			Offshore parks (1143 MW)		
PROB	990 MW			1190 MW		
<b>FRR NEED</b>	<b>1039 MW</b>			<b>1190 MW</b>		
aFRR NEED	145 MW			139 MW		
mFRR NEED	894 MW			1051 MW		
mFRR product mix	Min. 314 MW of R3 std	Rest = R3 flex	Sharing 50 MW	Min. 300 MW of R3 Std	Rest = R3 flex	Sharing 250 MW

# Downward FRR

# Rationale of Downward FRR needs

- Until 2019, negative LFC block imbalances (excess energy) were covered by FRR means of :
  - Balancing capacity of aFRR (R2)
  - Sharing agreements (formerly called inter-TSO contracts) with Tennet and RTE
  - Non-contracted bids for balancing energy (also called free bids or decremental bids)
- For 2019, the entry into operation of NEMO-link and new offshore wind parks, Elia had to analyze if the downward FRR needs are still covered.
  - SOGL requires to specify the dimensioning rules for downward FRR needs in the LFC block operational agreements and that Elia has sufficient reserve capacity to cover the FRR needs.
- Following its dynamic dimensioning study, Elia proposed to evolve gradually to a dynamic approach in which FRR needs are determined on daily basis :
  - For 2019 based on a simplified approach (outage only)
  - As from 2020 based on a more sophisticated method (machine learning) together with upward FRR needs

# Dimensioning of the downward FRR needs

- **Step 1: determination of the prediction risks**

- Static distribution of expected system imbalances (rolling time series of historic data M-2 – M-12).
- No upscaling or improvement factors is required (only filtering of forced outages)

- **Step 2: determination of the outage risk**

- Dynamic Forecast schedule of NEMO-link (day-ahead prediction of import, export, undecided and maintenance)
  - Impacts the N-1 (deterministic)
  - Impacts the outage probability distribution (Monte Carlo)

- **Step 3: determination FRR needs and aFRR / mFRR ratio**

- $\text{MAX}(\text{DET N-1}; \text{PROB99})$
- $\text{Besoins aFRR-} = \text{Besoins aFRR+}$

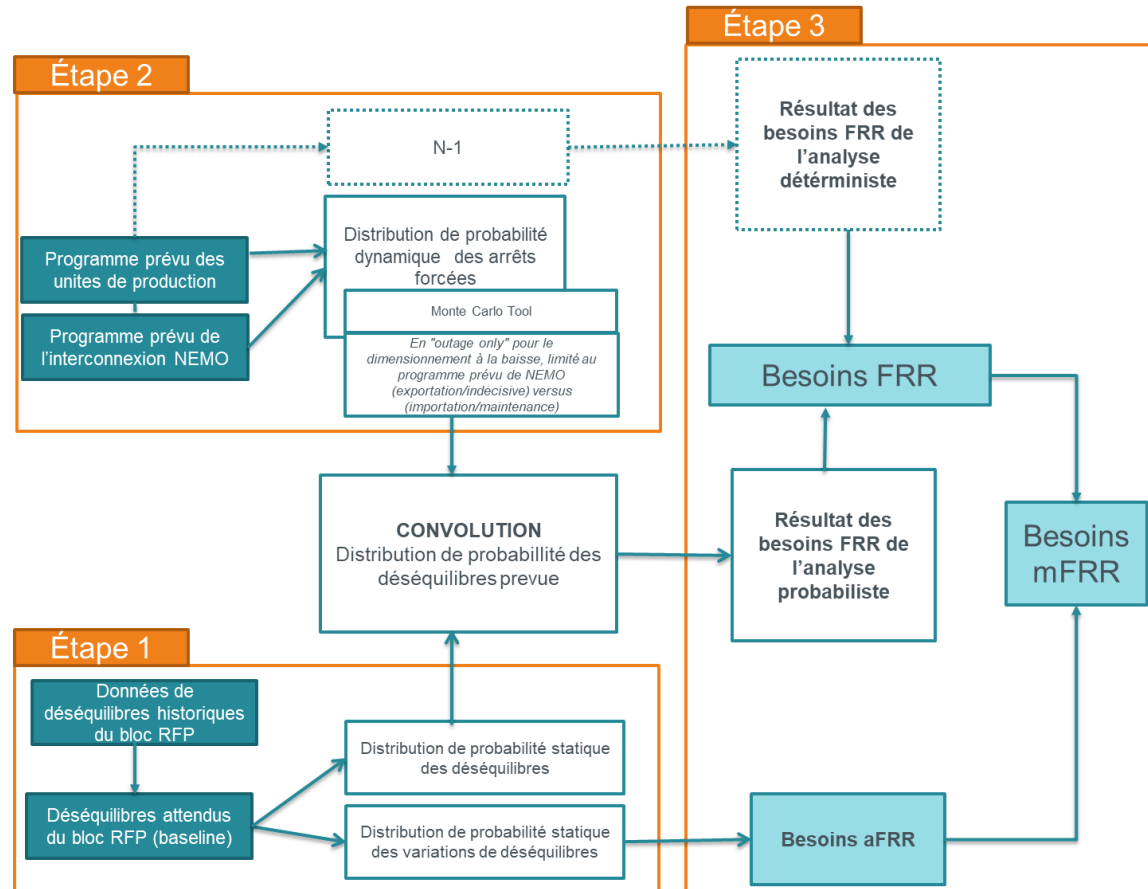

# Estimation of the FRR needs in 2018

- An estimation is conducted for 2019 (based on historic data of July 2018 – June 2019)
  - The expected system imbalances for 2019 are determined for a scenario in which NEMO-link is scheduled in import / export / maintenance / undecided. This results in practice in two distribution curves
    - The probabilistic methodology (99.0%) results in two figures :
      - 580 MW (NEMO-link export or undecided)
      - 530 MW (NEMO-link import or maintenance)
    - Taking into account the dimensioning incident, the FRR needs are determined as :
      - 1000 MW (NEMO-link export or undecided)
      - 530 MW (NEMO-link import or maintenance)

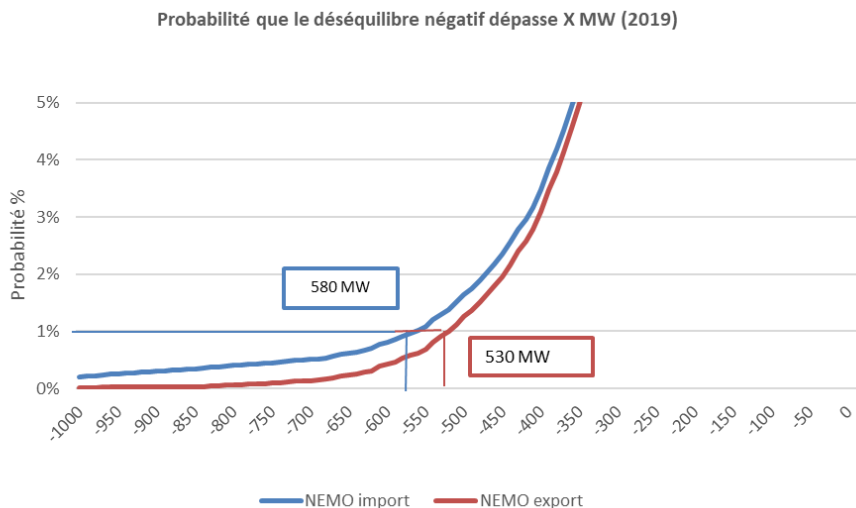

[MW]	Nemo Link en export (ou non déterminé)	Nemo Link en import (ou maintenance)
Besoins de FRR (Déterministe, N-1)	1000	0
Besoins de FRR (Probabiliste)	580	530
Besoins de FRR minimum (R2+R3-)	<b>1000</b>	<b>530</b>
Besoins d'aFRR (R2)	<b>145</b>	<b>145</b>
Besoins de mFRR (R3-)	<b>855</b>	<b>385</b>

# FRR means

- Sharing (with RTE and TENNET) compliant with SOGL
  - Limited by difference between N-1 and PROB99
  - Sharing can only be accounted when in export / undecided
- An analysis of available decremental bids show that a capacity of 400 MW and 500 MW is available in respectively 95,5% and 93,3% of the time
- Elia concludes sufficient coverage of the FRR needs without procuring balancing capacity taking into account expected system evolutions (e.g. bidladder)
- Elia will conduct an analysis with dynamic dimensioning results when having a full year of result for 2019.

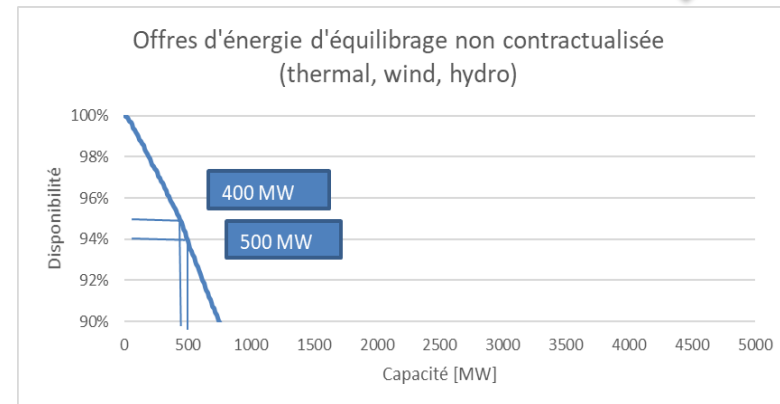
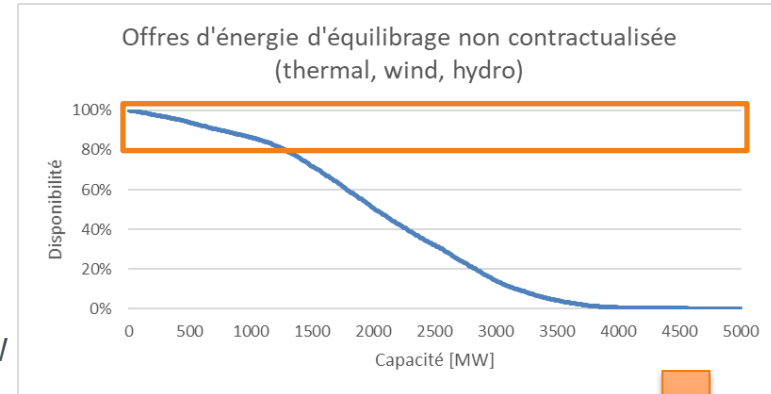

[MW]	NEMO en export (ou non déterminé)	NEMO en import (ou maintenance)
Besoins de FRR minimum (R2+R3-)	1000	530
Besoins d'aFRR (R2)	145	145
Besoins de mFRR (R3-)	855	385
Capacité d'équilibrage d'aFRR	145	145
Partage de réserves de mFRR et offres d'énergie d'équilibrage non contractée	> 855	> 855

# Summary Dossier Volume 2019

