

## General technical requirements of the submetering solutions

The following solutions are possible:

1. The use of a meter (Elia standard) that communicates directly the 1/4h-values of active/reactive power to the Elia metering data management system through a communication protocol known by Elia.
2. The use of a datalogger (Elia standard) that collects the metering pulses of a private meter and communicates the 1/4h-values of active/reactive power to the Elia metering data management system through a communication protocol known by Elia.
3. The use of a router 4G that communicates directly the 1/4h-values of active/reactive power coming from a private meter to the Elia metering data management system through a communication protocol known by Elia.

### Schematic view

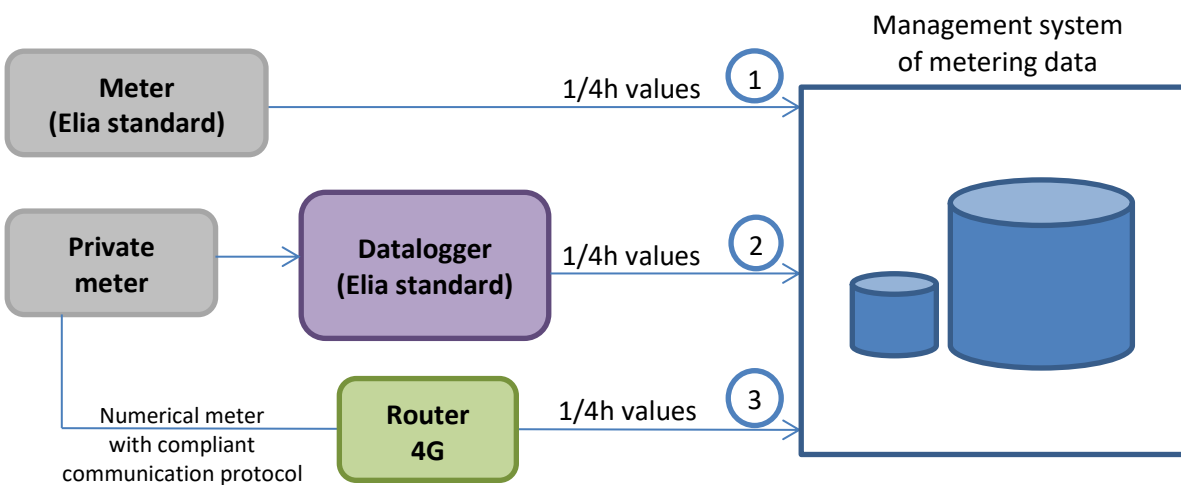

These solutions apply exclusively to Delivery Points within the electrical facilities of a grid user connected to the ELIA Grid.

The metering system meets the following minimum requirements:

### Common technical requirements applying to metering installations

- Options 1, 2 and 3 :
  - The accuracy class of the measurement core of current transformers (CT) corresponds ideally to 0.2S (according to EN-IEC 60044-1) and meets at least the requirements specified in the following table.
  - The accuracy class of the measurement core of voltage transformers (VT) corresponds ideally to 0.2 (according to EN-IEC 60044-2) and meets at least the requirements specified in the following table.
- Options 2 and 3 :
  - Only digital technology meters are accepted.
  - The accuracy class of the meter for active energy corresponds ideally to 0.2S (according to EN-IEC 62053-22) and meets at least the requirements specified in the following table.

Power of measured process	TP	TI	Wh-meter	Varh-meter
≥ 20 MVA	0.2	0.2s	0.2s	0.5
≥ 5 MVA à < 20 MVA	0.2	0.2	0.2	2
≥ 1 MVA à < 5 MVA	0.2	0.2	0.5	2
≥ 250 kVA à < 1 MVA	0.2	0.5	1	2

#### Common technical requirements applying to all metering installations

- Any cable connecting the current or voltage transformers to a meter must be as short as possible. The section of the connection wires between the meter and the current transformer is ideally minimum 4 mm<sup>2</sup>. The section of the connection wires between the meter and the voltage transformer is ideally minimum 10 mm<sup>2</sup>.
- The connection wires to current and voltage transformers may not be located in the same cable.
- An earthing terminal is available near the installation.
- The signal level for GSM must be sufficient to enable a communication with the Elia management system of metering data.
- The following communication protocols are allowed: EDMI, SCTM (till 09/2022), DLMS (as for 09/2022).

#### Specific technical requirements

Depending on the chosen option, the following requirements must be observed as well:

- Options 1 : Elia submeter
  - A system of 2 or 3 current / voltage transformers is allowed (method 2 or 3 power meters).
  - The current and voltage signals are available on a dedicated terminal.
  - The space for the installation of a Elia submeter is: L600 mm x H800 mm (indicative values).  
Note: on request, the metering pulses are made available to the grid user.
  - The antenna of the synchronization clock must be installed at a place ensuring good reception of the synchronization signal.
  - A power off of the electrical load downstream the meter to be installed is required for the installation and commissioning of the equipment.
- Option 2 : Datalogger (Elia standard) and private meter
  - The metering pulses for active energy are made available on a dedicated terminal (the impulse contacts are potential free).
  - The weight of the metering pulses is known (and programmable). If necessary, it will be adapted by Elia to ensure a maximum accuracy. Maximum pulse frequency: 4 Hz.
  - The space for the installation of a datalogger is: L400 x H800 (indicative values).
  - If a private datalogger is used, it must be equipped with an external synchronisation clock with accuracy better than 20 ms. Synchronization is necessary every 1/4h (top 15-min) or once daily provided that the accuracy of the data logger's internal clock is better than 1 s (maximal daily deviation).
  - A power off is not necessary for the installation and commissioning of the equipment.
- Option 3 : Private meter and router 4G
  - The autonomy of the memory of the meter is ideally greater than 30 days.
  - A specific communication port is available for connecting the router 4G.

## Submetering

---

- The weight of the metering pulses is known (and programmable). If necessary, it will be adapted by Elia to ensure a maximum accuracy. Maximum pulse frequency: 4 Hz.
- The space for the installation of the router is: L400 x H400 (indicative values).
- An external synchronization signal for the numeric meter is required. Synchronization is necessary each 1/4h (top 15-min) and the clock has an accuracy better than 20 ms (maximum admissible deviation per 1/4h). In case of disappearance of the external synchronization, the internal clock of the numeric meters may not have a deviation greater than 1 s (per day).
- A power off is not necessary for the installation and commissioning of the equipment.

-----oOo-----